

SAMSUNG

CDMA TELEPHONE SPH-A940

SERVICE *Manual*

CDMA TELEPHONE



CONTENTS

1. General Introduction
2. Circuit Description
3. Installation
4. NAM Programming
5. Product Support Tools
6. Test Procedure
7. Flow Chart of Troubleshooting
8. Exploded Views and Parts List
9. Block Diagram
10. Electrical Parts List
11. PCB Diagrams

**SAMSUNG
ELECTRONICS**



This Service Manual is a property of Samsung Electronics Co.,Ltd.
Any unauthorized use of Manual can be punished under applicable
International and/or domestic law.

© Samsung Electronics Co.,Ltd. November. 2005
Printed in Korea.

Code No.: GH68-08774A
BASIC.

1. General Introduction

1-1. General Instruction

The SPH-A940 enables mobile users to communicate 3G CDMA2000 1X service into a single handset.

For CDMA/PCS mode, The SPH-A940 supports Release A of the CDMA2000 1X standard.

The SPH-A940 is the first 2 mega pixel camera phone with 2x optical zoom and auto focus of Samsung for North America that works on North American CDMA networks.

This stylish clamshell phone supports dual color displays, Bluetooth, MMS, voice dialing, airplane mode and EV-DO services.

2. Circuit Description

2-1. Logic Section

2-1-1. Power Supply

Press "END" key to turn on the phone and then the **VBATT** and **ON_SW** signals will be connected. This turns on the inner regulators(**V_MSMCORE**, **V_MSMC**, **VPD**, **VPA**) of U203(MAX1526).

The **VBATT** applied to ON_SW will change ON_SW_SENSE signal from HIGH to LOW.

MSM6500(U101) sends out PS_HOLD(logical HIGH) to keep the inner regulators on even after the "END" key is released. **V_RFRX** can be turned on/off by the RX_CTRL signal. **V_TCXO** can be turned on/off by the TCXO_CTRL signal. The other regulators(**2.85VDD**, **V_SYNTH**, **V_RFTX**, **V_MOTOR**, **V_LED**) will be in the ON/OFF state by I²C-compatible 2 wire serial interface.

The regulated Voltage(U203, V_MSMCORE) are used in the core of MSM.

The regulated Voltage(U203, V_MSMC) are used in the digital part of MSM.

The regulated Voltage(U203, VPD) are used in the digital part MSM.

The regulated Voltage(U203, VPA) is used in the analog part of MSM.

The regulated Voltage(U203, V_RFTX) is used in the Tx RF part.

The regulated Voltage(U203, V_RFRX) is used in the Rx RF part.

The regulated Voltage(U203, V_TCXO) is used in the TCXO.

The regulated Voltage(U203, V_SYNTH) is used in the PLL part.

The regulated Voltage(U203, 2.85VDD) is used in the Camera Display part and the T-Flash.

The regulated Voltage(U203, V_MOTOR) is used in the MOTOR.

The regulated Voltage(U203, V_LED) is used in the KEYPAD LED.

2-1-2. Inner Charging Circuit Part

The most important function of the charger shall be done in the PMIC(Power Management Circuit U203).

When the phone with a battery is connected with a travel charging adapter, the inner charging circuit of the PMIC(U203) will charge the battery by constant fast charge mode.

When battery reaches regulation voltage of 4.2V (default charging voltage for Li+mode), the charge current drops quickly to 0mA

- Input voltage range : 4.25~6.5V
- Charging Temperature : 0°C~40°C
- Charging Method : Constant Voltage/Current -Charging Current : Normal 550mA
- Charging Time : Standard (1100mAh) 2.5 ~ 3 Hrs , Extended (1700mAh) 3.5 ~ 4 Hrs
- Charging Mode : ① Charging ② Completion

- Charging Battery Regulation Voltage

- ① Min 4.158V, Typical 4.2V, Max 4.242V(at T_A : 0°C to +85°C)
- ② Min 4.137V, Typical 4.2V, Max 4.263V(at T_A : -40°C to +85°C)

Universal Serial Bus Interface

SPH-A940 supports a Universal Serial Bus(USB) interface by the MSM6500, to provide an efficient interconnection between the mobile phone and a Personal Computer(PC).

The MSM6500's USB interface is designed to comply with the Universal Serial Bus Specification, Revision 2.0. An external USB transceiver(U203) is required to implement the USB interface.

2-1-3. Logic Part

The logic part consists of MSM, MEMORY, LCD, CAMERA, CCP, external MEMORY and other input and output peripherals.

MOBILE SYSTEM MODEM(U101:MSM6500)

Industry standard ARM926EJ-S microprocessor is embedded. The MSM6500 chipset integrates CDMA2000 1x and 1xEVDO service. The 1xEVDO solution can support High-speed peak data rates of 2.4Mbps on forward link and 153kbps on reverse link.

The MSM6500 device is offered in a 409 ball, 0.5mm pitch, CSP production package. Subsystems within the MSM6500 device include a CDMA processor, a QDSP for voice compression, an ARM9TDMI microprocessor. Also integrated in the MSM6500 device are analog functions such as an audio voice codec, PLL, transmit DACs, ADCs, memories, USB controller, peripheral interfaces, and an enhanced clock. It is one of the most important components of the CDMA cellular phone.

The interface circuitry consists of reset circuit, dual address/data bus and memory controls. The TCXO clock of 19.2Mhz is used as the main clock of SPH-A940 model.

MCP : NAND FLASH and SDRAM (U102(KBE00F003M))

MCP is consist of two 512Mbit(64M*8) NAND FLASH and two 256Mbit(4M*16*4Banks) Mobile SDRAM. NAND FLASH is used to store the Font data and program. EFS area is used to store ESN, NAM information, telephone directory, SMS messages and other important information of the phone, and also to store application programs and downloaded stuffs such as BREW applications and MP3. MCP is also used to excute the DMSS(Dual Mode Subscriber system) software.

Using the down-loading program, the program can be changed even after the terminal is fully assembled.

Keypad

For key recognition, key matrix is operated by using SCAN(0:7) and KEYSENCE(0:3) of the input ports of MSM. 23 backlight LEDs and back-light circuitry are included in the keypad for easy operation in the dark.

LCD Module

LCD is composed of a Transmissive with Micro Reflective(TMR) type Main TFT-LCD Panel, Transflective type Sub TFT-LCD Panel, a driver circuit and a back-light unit.

The resolution of a 2.0" Main LCD(TMR) contains 176 * 220 pixels, the resolution of a 1.17" Sub LCD(Transflective) contains 96 * 96 pixels.

Clock

CPU clock : 19.2MHz. Clock signal from the TCXO

Sleep clock : 32.768KHz. Clock signal for sleep.

TCXO/N : 19.2/N MHz. This clock source is used by various blocks of the MSM6500 device, such as the ARM9CORE, UARTs, general-purpose PDMs and TCXO is also used by the MSM6500 device to produce CHIPX8.

USB clock : 48MHz. Clock signal for the USB interface

CAMERA

The camera module consists of 1/3 type 2 Mega (2140K) Pixels CCD sensor, Digital signal processor, and MPU. The camera module provides Auto Focus, 2x Optical Zoom, Auto Exposure, and Auto White-Balance functionality.

CCP (Camera Control Processor)

CCP can support sensors up to 2M pixels. CCP directly transmits and previews the RGB data to the LCD graphic memory by processing the sensor output data according to the MSM's command and provides hardware based real-time JPEG compression and decompression. CCP can save the raw RGB data up to SVGA resolution into its image buffer and allows the host processor to download with scalable sized compressed data. In addition, CCP can download the compressed image to either store the original RGB data or transfer the image to the LCD.

Bluetooth module

Bluetooth module is a Bluetooth™ 1.1 and 1.2 compliant, stand-alone baseband processor with an integrated 2.4GHz transceiver. Bluetooth module supports any voice and/or data application that requires the Bluetooth SIG standard Host Controller Interface (HCI) via UART and PCM audio interfaces.

Operation Clock: 19.2MHz

Low-Power Clock: 32.768KHz

2-1-4. RF Interface Part

CDMA Data Interface

- TX_Q_P, TX_Q_N, TX_I_P, TX_I_N (U400) : Tx analog signal used during CDMA
- RX_I_P, RX_Q_P, RX_I_N, RX_Q_N (U302) : RX analog signal used during CDMA

RF Interface

- TX : TX_AGC_ADJ(U101) is used to control the TX power,
PA_ON_PCS(U101) is used to control the PCS power amplifier and
PA_ON_CELL(U101) is used to control the CDMA power amplifier.
- RX : TRK_LO_ADJ(U101) is used to compensate the TCXO module.

2-1-5. Audio Part

The MSM6500 device integrates a stereo wideband voice/audio CODEC into the Mobile Station Modem. The integrated CODEC contains all of the required conversion and amplification stages for the audio front end.

The CODEC operates as a 13bit linear CODEC with the transmit(TX) and receive(RX) filters designed to meet ITU-T G.712 requirements. The CODEC contains the software controlled amplifier for both the receiving and transmitting sections. Also, the vocoding schemes used will be 13kbps QCELP and 8Kbps EVRC. The QCELP vocoder is based in the MSM internally.

2-1-6. Tx Audio Path

The voice signal from the microphone is filtered and amplified by the internal OP-AMP and is converted to PCM data by the internal CODEC in the MSM. And then these signals are applied to the the MSM(U101)'s internal vocoder.

2-1-7. Rx Audio Path

The PCM data from the MSM(U101) is inputted to the internal CODEC and the data will be decoded by the internal DAC. Audio levels are adjusted by the amplifier. And then audio is sent to the receiver.

2-1-8. Speaker Path

When the MSM(U101) receives the data, its internal CMX generates bell and melody. The CMX bell and melody generated in MSM6500 are sent to SAPA1D2.

The SAPA1D2 (stereo class - D audio power amplifier) is a high quality audio power conversion chip generating 2.5W RMS output directly from the VBATT supply. It is a high efficiency audio amplifier for mobile applications. The gain of amplifier in SPH-A940 set to 4(V/V) . The output generated in SAPA1D2 is intended to drive two speakers.

2-1-9. Key Tone Generator

The CODEC data out from the MSM6500 is converted to DTMF signal by TONE generator of internal CODEC, which is then amplified by the internal audio amplifier to be sent to the receiver unit.

2-2. PCS Section

2-2-1. Receiver

LOW NOISE AMPLIFIER (U301)

The low noise amplifier(It is included in FC7510 : U301) amplifies a weak signal received from the base station to obtain the optimum signal level.

RF BAND PASS FILTER (F302)

The RF BPF(F302) passes only a specific frequency(1960 ± 30 MHz) from the signal received from the mobile station. The bandwidth is 60 MHz.

VOLTAGE CONTROLLED OSCILLATOR(OSC301)

The VCO(OSC301) generates the signal having 1715 ~ 1788MHz frequency range.

The VCO's output frequency is changed by control voltage. The PLL in S1M8690X generates this control signal and this signal is changed into DC control voltage by R-C Loop filter.

Frequency Synthesizer Circuit

The PLL(Phased Locked Loop) block consists of VC-TCXO(OSC302), PLL in S1M8690X and VCO(OSC301). Input reference frequency is generated at VC-TCXO(OSC302) and the RF local signal is generated at VCO. PLL compares the two signals and generates the desired signal with a preprogrammed counter which controls voltage.

VOLTAGE CONTROLLED TEMPERATURE COMPENSATED CRYSTAL OSCILLATOR (OSC302)

The VC-TCXO (OSC302) is a reference source of the frequency synthesizer. It provides 19.2MHz reference frequency to PLL-IC. It is a voltage controlled temperature compensated crystal oscillator having 19.2MHz ± 2.5 ppm frequency stability over all useful temperature range. A correct frequency tuning is made by the control voltage.

2-2-2. Transmitter

Intenna

Intenna sends signal to the base station and receives the signal from the base station. It is a tri-band Intenna and covers PCS band, CDMA band and GPS band.

RF Switch

It(U405) is used to switch the PCS path, the CDMA path and the GPS path, The RF signal passes through PCS & CDMA path when GPS_MODE is low. GPS_MODE is a digital signal from MSM6500 GPIO.

Duplexer

Duplexer(F402) allows to transmit only the signals within acceptable Tx frequency range (1880 \pm 30 MHz) through the Intenna.

It provides the appropriate attenuation of transmitted signal at the receiver input and the appropriate rejection of the transmit-generated noise in the Receiver band.

Power Amp

Power amplifier module(U404:ACPM-7833-DC1) amplifiers signal to be sent to the base station through the antenna.

Driver Amp

The driver amp(U400 ; included in S1M8690X) allows the signal to be inputted to the power amp(U404) as a specified level.

Up-converter(Mixer)

The up-converter(U402 ; also included in S1M8690X) receives the local signal $F_{Tx} * 0.7999$ and signal controlled by TX AGC amp(in S1M8690X) to generate Tx RF signal 1880±30MHz which signal comes out from the mixer output by adding $F_{Tx} * 0.7999$ local signal.

F_{Tx} means TX RF signal Frequency.

Automatic Gain Control Amp

The TX IF AGC amp (in S1M8690X) controls gain of AGC to deliver power level needed at driver amp. Its control voltage varies from 0.2V to 2.5V.

2-3. CDMA Section

2-3-1. Receiver

Low Noise Amplifier(LNA)

The low noise amplifier(It is included FC7510 : U301) amplifies a weak signal received from the base station to obtain the optimum signal level.

RF Band Pass Filter(Rx RF SAW Filter)

The RF BPF in F301 passes only a specific frequency(881.49±12.5 MHz) from the signal received from the mobile station. The bandwidth is 25 MHz.

Voltage Controlled Oscillator

The VCO(OSC301) generates the signal having 1715 ~ 1788MHz frequency range.

The VCO's output frequency is changed by control voltage. The PLL in S1M8690X generates this control signal and this signal is changed into DC control voltage by R-C Loop filter.

Frequency Synthesizer Circuit

The PLL(Phased Locked Loop) block consists of VC-TCXO(OSC302), PLL in S1M8690X and VCO(OSC301). Input reference frequency is generated at VC-TCXO(OSC302) and the RF local signal is generated at VCO. PLL compares the two signals and generates the desired signal with a preprogrammed counter which controls voltage.

VC-TCXO

The VC-TCXO (OSC302) is a reference source of the frequency synthesizer. It provides 19.2MHz reference frequency to PLL-IC. It is a voltage controlled temperature compensated crystal oscillator having 19.2MHz ± 2.5 ppm frequency stability over all useful temperature range. A correct frequency tuning is made by the control voltage.

2-3-2. Transmitter

Intenna

Intenna sends signal to the base station and receives the signal from the base station. It is a tri-band Intenna and covers PCS band, CDMA band and GPS band.

RF Switch

It(U405) is used to switch the PCS path, the CDMA path and the GPS path, The RF signal passes through PCS & CDMA path when GPS_MODE is low. GPS_MODE is a digital signal from MSM6500 GPIO.

Duplexer

Duplexer(F405) passes the RF signal of Rx frequency range(881.49 ± 12.5 MHz) and Tx frequency range (836.49 ± 12.5 MHz). It provides appropriate attenuation of transmitted signal at the receiver input and appropriate rejection of the transmit-generated noise in the Receiver band. It also matches LNA input in receiving part and PAM(U403:ACPM-7813) output in transmitting part with the Intenna.

Power Amp

Power amplifier module(U403:ACPM-7813-DC1) amplifiers signal to be sent to the base station through the antenna.

RF Band Pass Filter(Tx RF SAW Filter)

The RF BPF(F404) passes only specific frequency($836.49 \pm 12.5\text{MHz}$) to send it to power amp(U403:ACPM-7813-DC1).

Driver Amp

The driver amp(U402 ; It is included in S1M8690X) allows the signal to be inputted to the power amp(U403) as a specified level.

Up-Converter(Mixer)

The up-converter(U402 ; It is also included in S1M8690X) receives the local signal $F_{\text{Tx}} * 1.6666$ and the signal controlled by TX AGC amp(in S1M8690X) to generate Tx RF signal $836.49 \pm 12.5\text{MHz}$ signal comes out from the mixer output by adding $F_{\text{Tx}} * 1.6666$ local signal. F_{Tx} means TX RF signal Frequency.

Automatic Gain Control Amp

The TX IF AGC amp in S1M8690X controls gain of AGC to deliver power level to be needed at Driver amp. Its control voltage varies from 0.2V to 2.5V.

2-4. GPS Section

Antenna

Antenna receives a signal from GPS satellites.

It is a tri-band Antenna and covers PCS band, CDMA band and GPS band.

RF Switch

It(U405:TQP4M3018) is used to switch the PCS path and CDMA path and the GPS path. The RF signal passes through PCS path when PCS_MODE is high(2.6V). The RF signal passes through CDMA path when CELL_MODE is high(2.6V). The RF signal passes through GPS path when GPS_MODE is high(2.6V). PCS_MODE, CELL_MODE and GPS_MODE are digital signals from MSM6500 GPIO.

Low Noise Amplifier(LNA)

The low noise amplifier(Q302:ATF55143) amplifies a weak signal received from the base station to obtain the optimum signal level.

RF Band Pass Filter(Rx RF SAW Filter)

The RF BPF(F303:DG75BS1) passes only a specific frequency(1575.42 ± 1 MHz) from the signal received from the satellite. The bandwidth is 2 MHz.

3. Installation

3-1 Installing and Removing the Battery

To install, insert the battery into the opening on the back of the phone making sure the plastic tabs on the back are inserted into the matching slots in the phone. Press down until the latches snap into place.

To remove, make sure the power is off. Push the battery release latch up completely. Pull and lift the battery away from the phone.

3-2 Using the Desktop Charger

1. Plug the AC cord from the charger into the electrical outlet.
2. Insert the phone into the slot.

A red light on the charger lets you know the battery is charging.

A green light lets you know that the battery is at least 90 percent charged.

A orange light indicates that the battery is operating at a temperature that is too high or low, or that the charger is not plugged in correctly. Please check the charger and the battery.

Specifications using DTC (Desktop Charger)

Battery Type	Standard Battery (Li-ion, 1000mAh)	Extended Battery (Li-ion, 1700mAh)
Charging	< 5 hours	< 5 hours
SEC Code	GH43-02160A	GH43-02161A

4. NAM Programming

NAM features can be programmed as follows:

Notes:

For example, press 'menu' and cursor to 'settings & tools' and '*', then press '000000' (000000: SPC code), you can see 'Service' Mode.

NAM SETTING FLOW:

LCD Display	Key in	Function
Service Mode		
1. ESN *** ***** (Decimal number) ***** (Hexa Number)	Enter ()	-Electronic Serial Number of the phone is displayed
2. AKEY AKEY	number Enter	AKEY Setup. - To input AKEY, enter AKEY #. - Stores it
3. Network Setting -1 Phone Number Phone Number(MDN) 0000006034	Enter (OK), and then enter the number	The phone number screen enables you to edit the phone number
3. Network Setting -2 MCC MCC 310	Enter the number	The MCC screen allows you to view and modify the mobile country code.
3. Network Setting -3 NMSID NMSID(NATIONAL MOBILE STATION ID) 00000006034	Enter the number	
3. Network Setting -4 True IMSI MCC True IMSI MCC 000	Enter the number	IMSI_S screen allows you to view and modify the international mobile station identity
3. Network Setting -5 True IMSI NMSID True IMSI NMSID 00000006034	Enter the number	

<p>3. Network Setting -6 PRL Enabled</p> <p>PRL Enabled Yes No</p>		<p>The PRL screen shows if the preferred roaming list (PRL) is enabled.</p>
<p>3. Network Setting -7 Home SID/NID</p> <p>Enter SID 2004 Enter NID 65535</p>	<p>Enter the number</p>	<p>This screen allows you to view and modify the various home system ID (SID) and network ID (NID) settings.</p>
<p>3. Network Setting -8 CDMA Pri Chn A</p> <p>CDMA Pri Chn A 283</p>	<p>Enter the number</p>	<p>The primary channel A screen allows you to view and modify primary channel A.</p>
<p>3. Network Setting -9 CDMA Sec Chn A</p> <p>CDMA Sec Chn A 691</p>	<p>Enter the number</p>	<p>The secondary channel A screen allows you to view and modify secondary channel A.</p>
<p>3. Network Setting 10 CDMA Pri Chn B</p> <p>CDMA Pri Chn B 384</p>	<p>Enter the number</p>	<p>The primary channel B screen allows you to view and modify primary channel B</p>
<p>3. Network Setting -11 CDMA Sec ChnB</p> <p>CDMA Sec Chn B 777</p>	<p>Enter the number</p>	<p>The secondary channel B screen allows you to view and modify secondary channel B.</p>
<p>3. Network Setting 12 Home Sys Reg</p> <p>Home Sys Reg Yes No</p>		<p>Home SID Reg – home system ID</p>
<p>3. Network Setting -13 Forgn SID Reg</p> <p>Forgn SID Reg Yes No</p>		<p>Foreign SID Reg – foreign system ID</p>

<p>3. Network Setting -14 Forgn NID Reg</p> <p>Forgn NID Reg Yes No</p>		<p>Foreign NID Reg – foreign network ID</p>
<p>3. Network Setting -15 Access Overload Class</p> <p>Access Overload Class 4</p>	<p>Enter the number</p>	<p>The overload class screen allows you to view and modify the overload class.</p>
<p>3. Network Setting -16 Origination Voice</p> <p>Orgination Voice SO EVRC 13k</p>		
<p>4. SMS Settns SMS UTC time</p> <p>Yes No</p>		<p>Selecting the SMS settings option allows you to view and edit the short message services (SMS).</p>
<p>5. Slot Cycle Index Slot Cycle Index</p> <p>1</p>	<p>Enter the number</p>	<p>This option allows you to view and modify the slot cycle index. To modify the index, select Edit</p>
<p>6. Service Programming Code</p> <p>Service Programming Code</p> <p>000000</p>	<p>Enter the number</p>	

5. Product Support Tools

5-1. General

IMPORTANT INFORMATION

Purpose

The Product Support Tool (PST) offers you the ability to interface with the SAMSUNG mobile phone using a PC. With this tool you can program the phones network system requirements and functionality, data, and download software upgrades. This document supports SamsungPST(Samsung Product Support Tool).

EQUIPMENT REQUIRED

Make sure you have the following equipment setup:

1. Minimum PC configuration: 586 CPU, 64MB RAM, Windows2000/XP and above, 5MB of disk space free for software upgrade.
2. PST Software with appropriate cable (USB Cable for SAMSUNG mobile phone).
3. USB Port.
4. Power Supply (3.8 V) or Battery.

INSTALLATION

1. Insert the SPH-A940 CDROM into your CD-Rom drive.
2. Run the file explorer and run the Setup.exe file.
3. After SamsungPST is installed on a computer, connect the phone, cable, and PC .

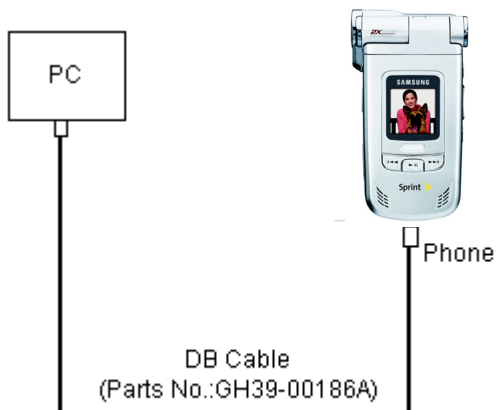

5-2. PST (Product Support Tool)

5-2-1 Getting Started

MAIN MENU SCREEN

1. Double Click on your "Samsung PST for Verizon (SE)"
2. Select SPH-A940

The Main Menu Screen shows the basic tasks that are available.

CAUTION: DO NOT attempt to program phone with a low battery.

5-2-2 Operation Procedure

Information

Click "Read general Information" icon.

Software Download

If the phone works normally, you must proceed below procedures.

Normal Download.

1. Connect PC and SPH-A940 with usb cable
2. Check com port of SAMSUNG CDMA Modem. To check on Com port, first you go to my computer->property->Hardware->Device Manager ->Modem->Samsung USB Modem. Then go to property of Samsung USB Modem, and then click on Modem tab. You may see the port number, which is assigned for Samsung USB Modem.
3. Run Samsung PST.
4. Change PST's comport setting (Setup COM Setting) same as com port of 'SAMSUNG cdma modem'
5. Select SPH-A940 and then click SW(Software Download) tab.
6. Select 'Normal' in software download option.
7. Click 'openfile' icon and select the bin file.
8. Click 'Start Software Download' icon.
10. When the downloading process is finished, the A970 power on automatically and the PST shows "Downloading completed!!".

If the phone doesn't works normally, you must proceed below procedures.

Emergency Download.

1. SPH-A940 enters the emergency mode(press simultaneously '9' and 'PWR')
2. Connect PC and SPH-A940 with usb cable
3. Check com port of SAMSUNG CDMA Modem. To check on Com port, first you go to my computer->property->Hardware->Device Manager ->Modem->Samsung USB Modem. Then go to property of Samsung USB Modem, and then click on Modem tab. You may see the port number, which is assigned for Samsung USB Modem.

4. Run Samsung PST.
5. Change PST's comport setting (Setup COM Setting) same as com port of 'SAMSUNG cdma modem'
6. Select SPH-A940 and then click SW(Software Download) tab.
7. Select 'Emergency' in software download option.
8. Click 'openfile' icon and select the bin file.
9. Click 'Start Software Download' icon.
10. When the downloading process is finished, the A970 power on automatically and the PST shows "Downloading completed!!".

PRL Download

1. Click "Open PRL1 file" icon and select the PRL file.
2. Click "Start PRL Download" icon.
3. When the downloading process is finished, the A970 will reboot automatically and the PST shows "Completed PRL Programming"

ERI Download

1. Click "Open ERI1 file" icon and select the PRL file.
2. Click "Start ERI Download" icon.
3. When the downloading process is finished, the A970 will reboot automatically and the PST shows "Completed ERI Programming"

Setting

Read Data from File

Click "Open mmc" icon to select the name of a file whose extension is "mmc". The values will be read from the named file, and will initialize the parameter values seen on the Settings screen

Read Data from Phone

Click Read from the Phone icon to upload the current programmable parameters of the phone. The values are read from the phone, so the phone must have the power ON and be properly connected to the PST.

NOTE: To actually view the data you need to go to the Edit Items screens.

Edit Items

Click this icon to edit Number Assignment Module (NAM) items or UI items.

1. GeneralNAM : Slot Cycle Index, Service Code
2. NAM1

Save Data to File

Click this icon to save the current parameters to a file. Once you enter a filename, Click <OK> button to write all current parameters to that file. This way the same information can be downloaded into multiple phones.

Write to Phone

Click this icon to write the selected parameter values to the phone. Writing the selected values to the phone may take up to a minute. If there are dependencies in a field you can make all the changes in the proper fields and download the information all together.

If you intend to use this write to Phone? feature, it is recommended that you do a "Read Data from Phone" first, and then make the changes, so that nothing gets inadvertently overwritten.

NOTE: DO NOT TOUCH THE PHONE WHILE WRITING IS IN PROGRESS.

Transfer

Backup Items

1. Select Item to backup in 'Item option' list.
2. Select 'backup' in 'Backup or Restore' list.
3. Click "Start Backup of Restore" icon.

6. Test Procedure

6-1 List of Equipment

- DC Power Supply
- Test Jig
- Test Cable
- CDMA Mobile Station Test Set HP8285A, HP8960, CMD-80, etc
- Spectrum Analyzer(include CDMA Test Mode) HP8596E,

6-2 Configuration of Test

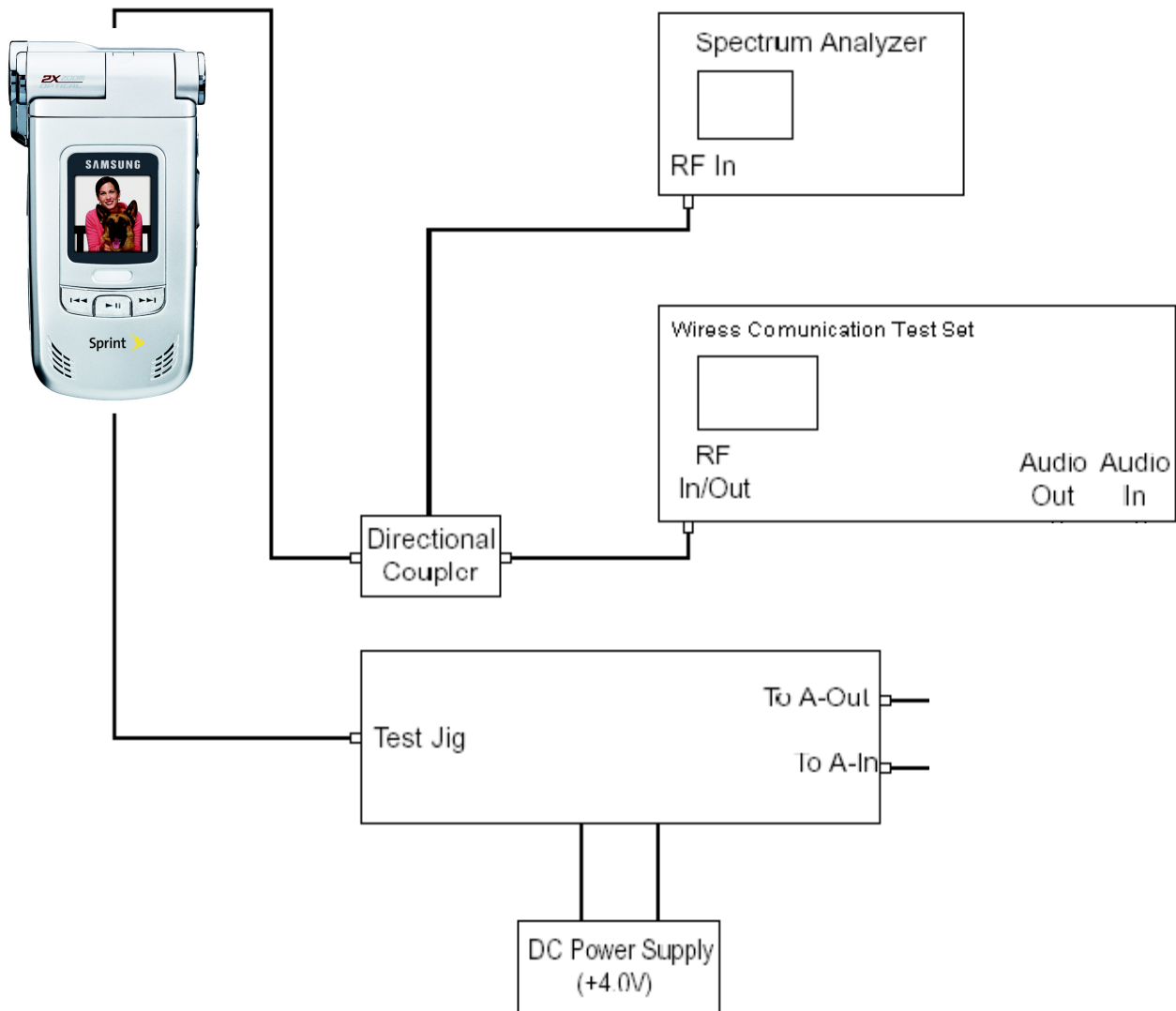

6-3 TEST CABLE CONNECTIONS

6-3-1 TEST CABLE

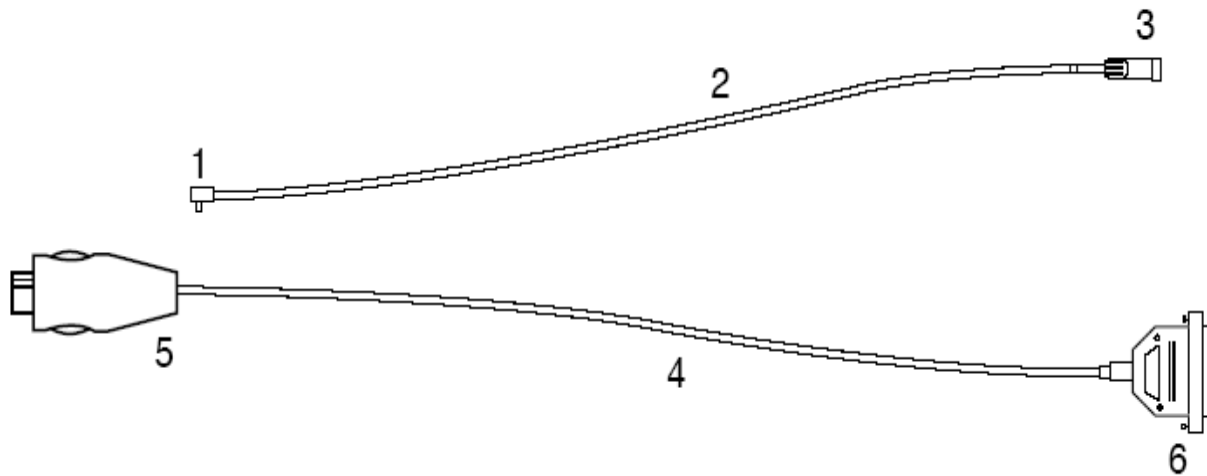

6-3-2 TEST CABLE CONNECTIONS

1	MHC 172
2	RF CABLE (1.4dB Loss for CDMA, 2.1dB Loss for PCS, 1.8dB Loss for GPS)
3	BNC CONNECTOR (RF)
4	DATA CABLE
5	Plug Connect to SPH-A940
6	Dsub 25PIN CONNECTOR (DATA)

6-3-3 Dsub 25 PIN CONNECTOR PIN DESCRIPTION (TEST CABLE 1, BACK SIDE)

DATA DESCRIPTION	Dsub CONN. PIN NO.	DATA DESCRIPTION	Dsub CONN. PIN NO.
GND	13	GND	24,25 (SHORT)
VBATT	4	VBATT	5,6 (SHORT)
HP_PWR	7	DP_RX_DATA	21
RX_AUDIO	12	DP_TX_DATA	22
TX_AUDIO	10		

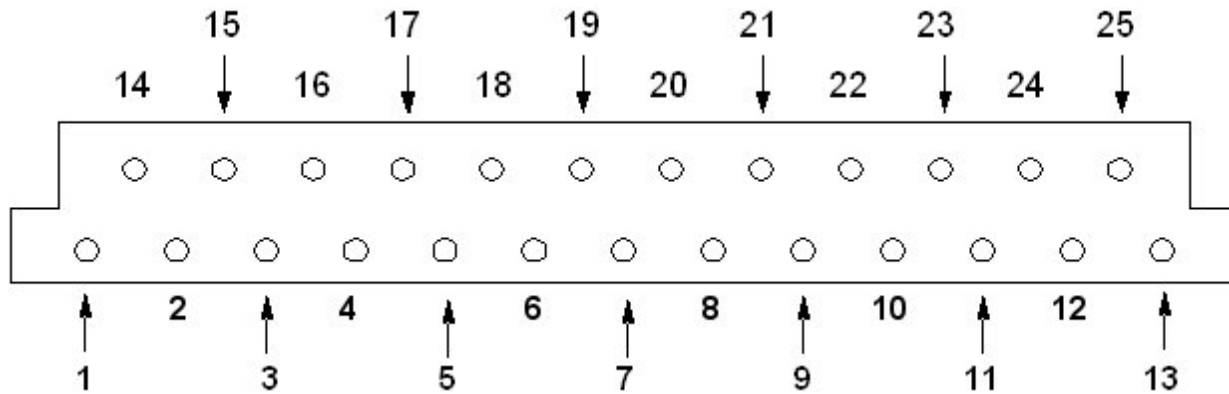

6-3-4 CONVERSION TABLE OF FREQUENCY vs CHANNEL

- CDMA/PCS

T Y P E	C H A N N E L	C O N V E R S I O N E Q U A T I O N	R E M A R K
TX FREQUENCY	$990 \leq N \leq 1023$ $1 \leq N \leq 779$	$F = 0.03 \times (N - 1023) + 825.00$ $F = 0.03 \times N + 825.00$	N ; CH NUMBER F ; FREQUENCY (CDMA)
RX FREQUENCY	$990 \leq N \leq 1023$ $1 \leq N \leq 779$	$F = 0.03 \times (N - 1023) + 875.00$ $F = 0.03 \times N + 875.00$	
TX FREQUENCY	$0 \leq N \leq 1199$	$F = 0.05 \times N + 1850.00$	N ; CH NUMBER F ; FREQUENCY (PCS)
RX FREQUENCY	$0 \leq N \leq 1199$	$F = 0.05 \times N + 1930.00$	

6-4 Test Procedure

6-4-1 CDMA/PCS mode

- Change the test mode

A. To change the phone's state from Normal Mode to Test Mode, You should enter the following keys.

: Press [4 7 * 6 8 # 1 3 5 8 0]

B. The command "0 0 1" is Suspend.

C. The command "0 2 2" is mode and channel change.

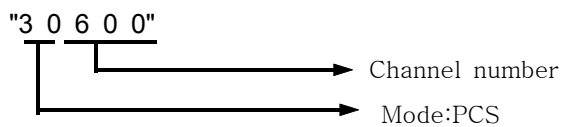
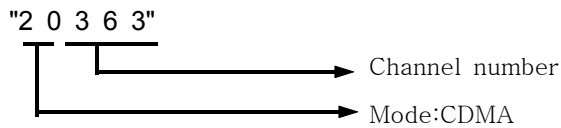

and press enter key from the soft key board to save mode/channel value..

D. The command "0 0 1" is Suspend.

E. To finish the Test Mode, You should enter the command "0 0 2".

6-4-2 Channel selection and Tx power output level control

CDMA

A. Enter to Test Mode [4 7 * 6 8 # 1 3 5 8 0]

B. "0 0 1" : Suspend.

C. The command "0 2 2" is mode and channel change

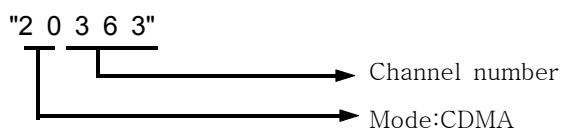

Push the [OK] key to save.

Test Procedure

D. To finish the Test Mode, You should enter the command "0 0 2".

E. Enter to Test Mode [4 7 * 6 8 # 1 3 5 8 0]

F. "0 0 1" : Suspend.

G. "0 1 1" : Carrier_On.

H. "0 1 4" : CDATA.

I. "0 9 2" : PA_RANGE_1.

J. "0 1 9" : Adjust RF power level.

PCS

A. Enter to Test Mode [4 7 * 6 8 # 1 3 5 8 0]

B. "0 0 1" : Suspend.

C. The command "022" is mode and channel change

"3 0 6 0 0"

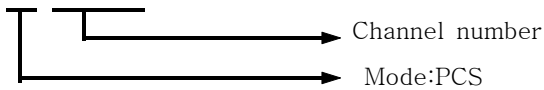

Push the [enter] key to save.

D. To finish the Test Mode, You should enter the command "0 0 2".

E. Enter to Test Mode [4 7 * 6 8 # 1 3 5 8 0]

F. "0 0 1" : Suspend.

G. "0 1 1" : Carrier_On.

H. "0 1 4" : CDATA.

I. "0 9 2" : PA_RANGE_1.

J. "0 1 9" : Adjust RF power level.

- CDMA Test items

TEST ITEMS	PROCEDURE
1. PREPARANCE	<p>Set test equipments up.</p> <p>[4 7 * 6 8 # 1 3 5 8 0] : Enter the Test Mode "0 0 1" : Suspend Confirm that the phone is in the "CDMA Mode". (If not CDMA Mode, Use Test Command "022""2XXXX" and Push the "↵" Key to "OK", and enter "0 0 2" to restart)</p> <p>If you select a wrong key, press " # ", then enter new command. To exit the Test Mode at any time, just press [0 0 2].</p>
2. FREQUENCY ACCURACY	<p>"0 0 1" : Suspend. "0 1 3 0 3 6 3 * " : Set channel to 363. "0 1 1" : Carrier On. "0 1 4" : Spread spectrum. "0 1 9 X X X ' END[Push and Hold] ' " : Set AGC Code(XXX) level. Measure the TX frequency : 835.89MHz±300Hz.</p>
3. OCCUPIED CDMA BANDWIDTH	<p>"0 0 1" : Suspend. "0 1 3 0 3 6 3 * " : Set channel to 363. "0 1 1" : Carrier On. "0 1 4" : Spread spectrum. "0 1 9 X X X ' END[Push and Hold] ' " : Enter AGC Code(XXX) to adjust RF Output Power.</p> <p>Measure the bandwidth (spec: 1.23MHz).</p>
4. LIMITATIONS ON EMISSIONS	<p>"0 0 1" : Suspend. "0 1 3 0 3 6 3 * " : Set channel to 363. "0 1 1" : Carrier On. "0 1 4" : Spread spectrum. "0 9 2" : PA_RANGE_1. "0 1 9 X X X ' END[Push and Hold] ' " : Enter AGC Code(XXX) to adjust RF Output Power.</p> <p>Measure the spurious at $F_c \pm 900\text{kHz}$, $F_c \pm 1.98\text{MHz}$, $2F_c$, $3F_c$, $1/2F_c$. spec: $F_c \pm 900\text{kHz}$ below 42dBc/30kHz $F_c \pm 1.98\text{MHz}$ below 54dBc/30kHz Outside Receive Band $43 + 10\log(PY)$ PY: Mean Output Power in watts</p>
5. GATED POWER & TIME	<p>Set the service option 2. Set the data rate Eighth (1200bps). Registering: HHP → HP8924C. Call : HP8924C → HHP. Measure the Gated Power & Time. spec : Gated Power - at least 20dB Gated Time - Rising Time : below 6μs Falling Time : below 6μs Burst Time : below 1.25ms</p>

- PCS Test items

TEST ITEMS	PROCEDURE
1. PREPARANCE	<p>Set test equipments up.</p> <p>[4 7 * 6 8 # 1 3 5 8 0] : Enter the Test Mode</p> <p>"0 0 1" : Suspend</p> <p>Confirm that the phone is in the "PCS Mode". (If not PCS Mode, Use Test Command "022""3XXXX" and Push the [OK] Key, and enter "0 0 2" to restart)</p> <p>If you select a wrong key, press " # ", then enter new command. To exit the Test Mode at any time, just press [0 0 2].</p>
2. FREQUENCY ACCURACY	<p>"0 0 1" : Suspend.</p> <p>"0 1 3 0 6 0 0 * " : Set channel to 600.</p> <p>"0 1 1" : Carrier On.</p> <p>"0 1 4" : Spread spectrum.</p> <p>"0 1 9 X X X ' END[Push and Hold] ' " : Set AGC Code(XXX) level.</p> <p>Measure the TX frequency : 1880.00MHz±300Hz.</p>
3. OCCUPIED CDMA BANDWIDTH	<p>"0 0 1" : Suspend.</p> <p>"0 1 3 0 6 0 0 * " : Set channel to 600.</p> <p>"0 1 1" : Carrier On.</p> <p>"0 1 4" : Spread spectrum.</p> <p>"0 1 9 X X X ' END[Push and Hold] ' " : Enter AGC Code(XXX) to adjust RF Output Power.</p> <p>Measure the bandwidth (spec: 1.23MHz).</p>
4. LIMITATIONS ON EMISSIONS	<p>"0 0 1" : Suspend.</p> <p>"0 1 3 0 6 0 0 * " : Set channel to 600.</p> <p>"0 1 1" : Carrier On.</p> <p>"0 1 4" : Spread spectrum.</p> <p>"0 9 2" : PA_RANGE_1.</p> <p>"0 1 9 X X X ' END[Push and Hold] ' " : Enter AGC Code(XXX) to adjust RF Output Power.</p> <p>Measure the spurious at $F_c \pm 1.25\text{MHz}$ spec: $F_c \pm 1.25\text{MHz}$ below 42dBc/30kHz</p>
5. GATED POWER & TIME	<p>Set the service option 2.</p> <p>Set the data rate Eighth (1200bps).</p> <p>Registering: HHP → HP8924C.</p> <p>Call : HP8924C → HHP.</p> <p>Measure the Gated Power & Time.</p> <p>spec : Gated Power - at least 20dB</p> <p>Gated Time - Rising Time : below 6μs</p> <p>Falling Time : below 6μs</p> <p>Burst Time : below 1.247ms</p>

7. Flow Chart of TroubleShooting

7-1 Logic Section

7-1-1 Power On

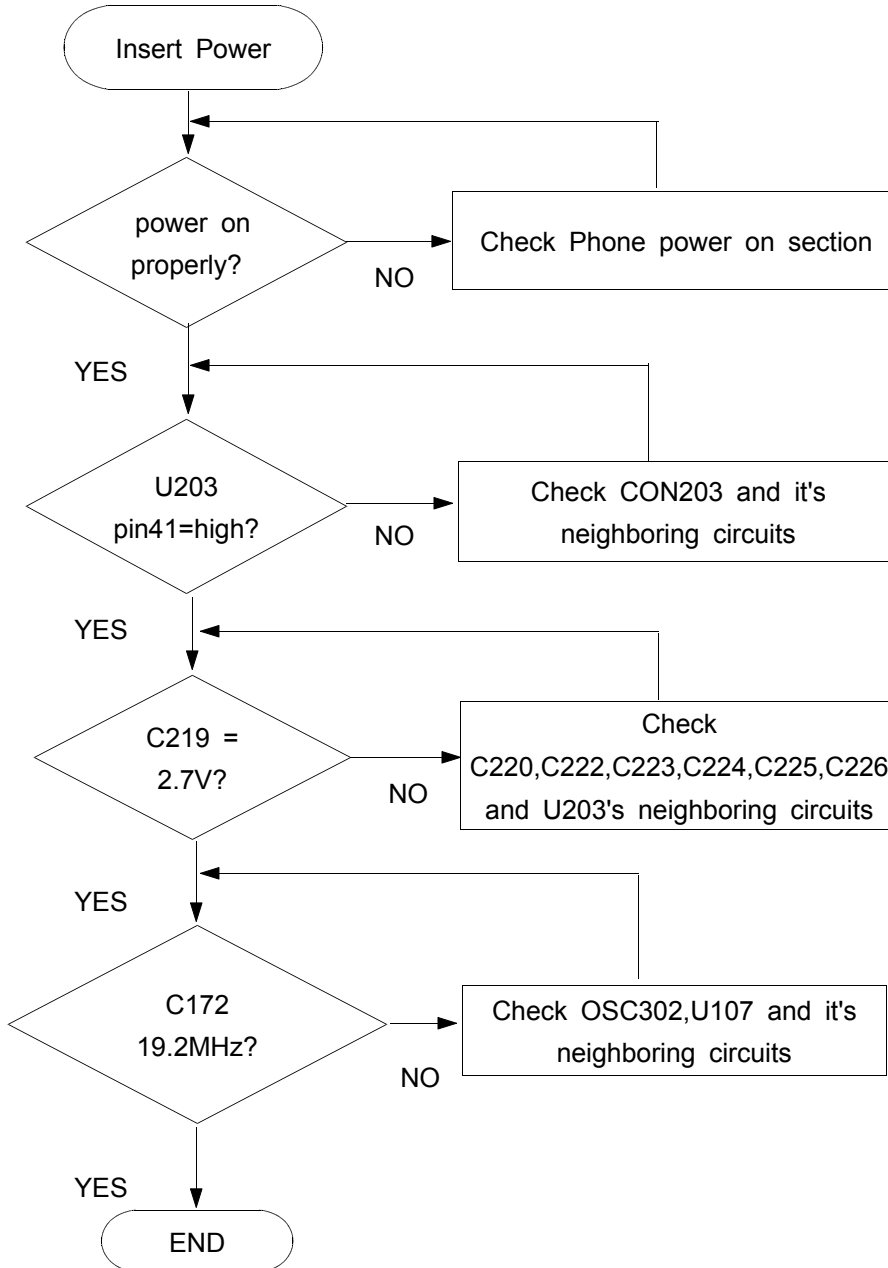

Flow Chart of Troubleshooting

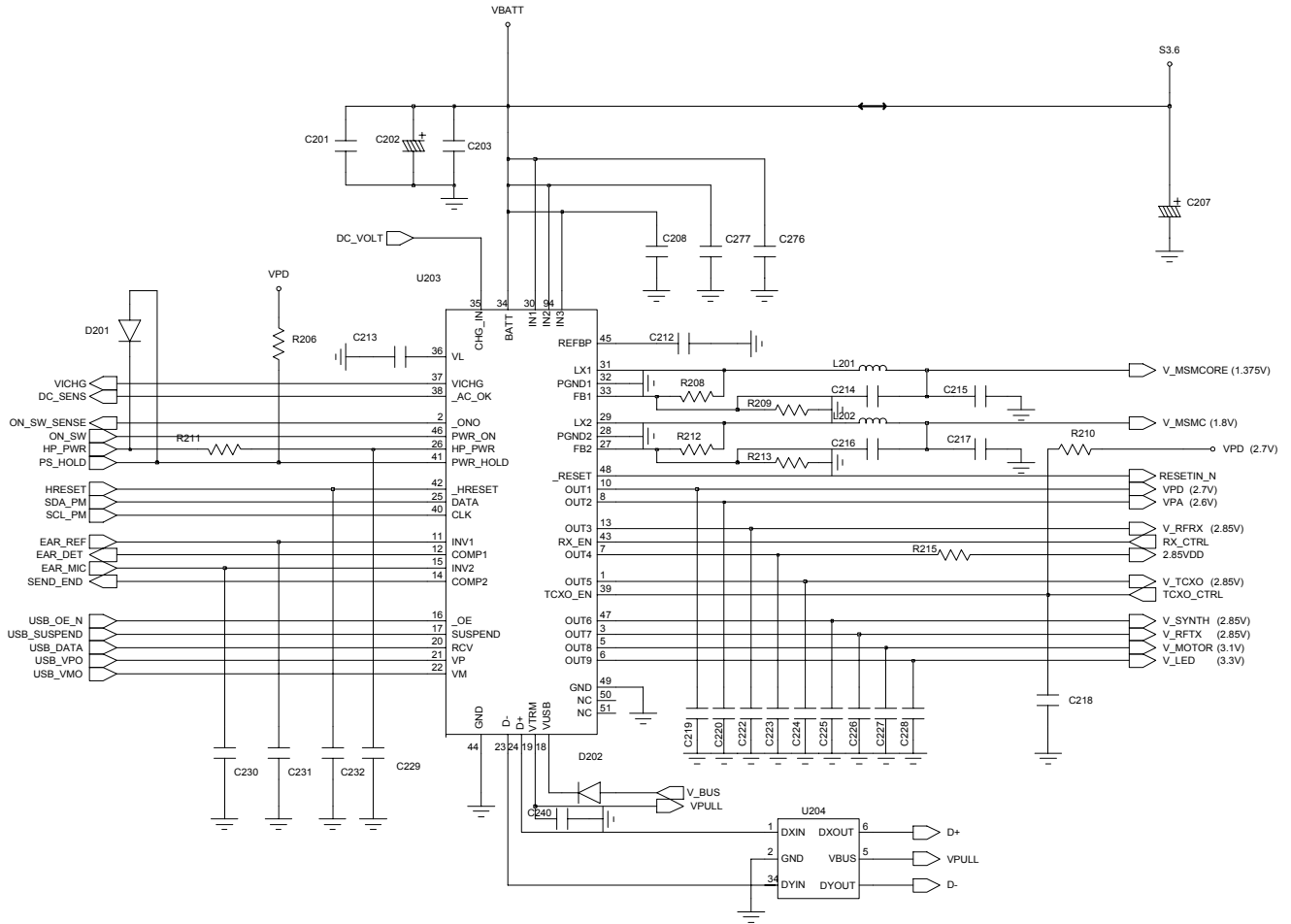

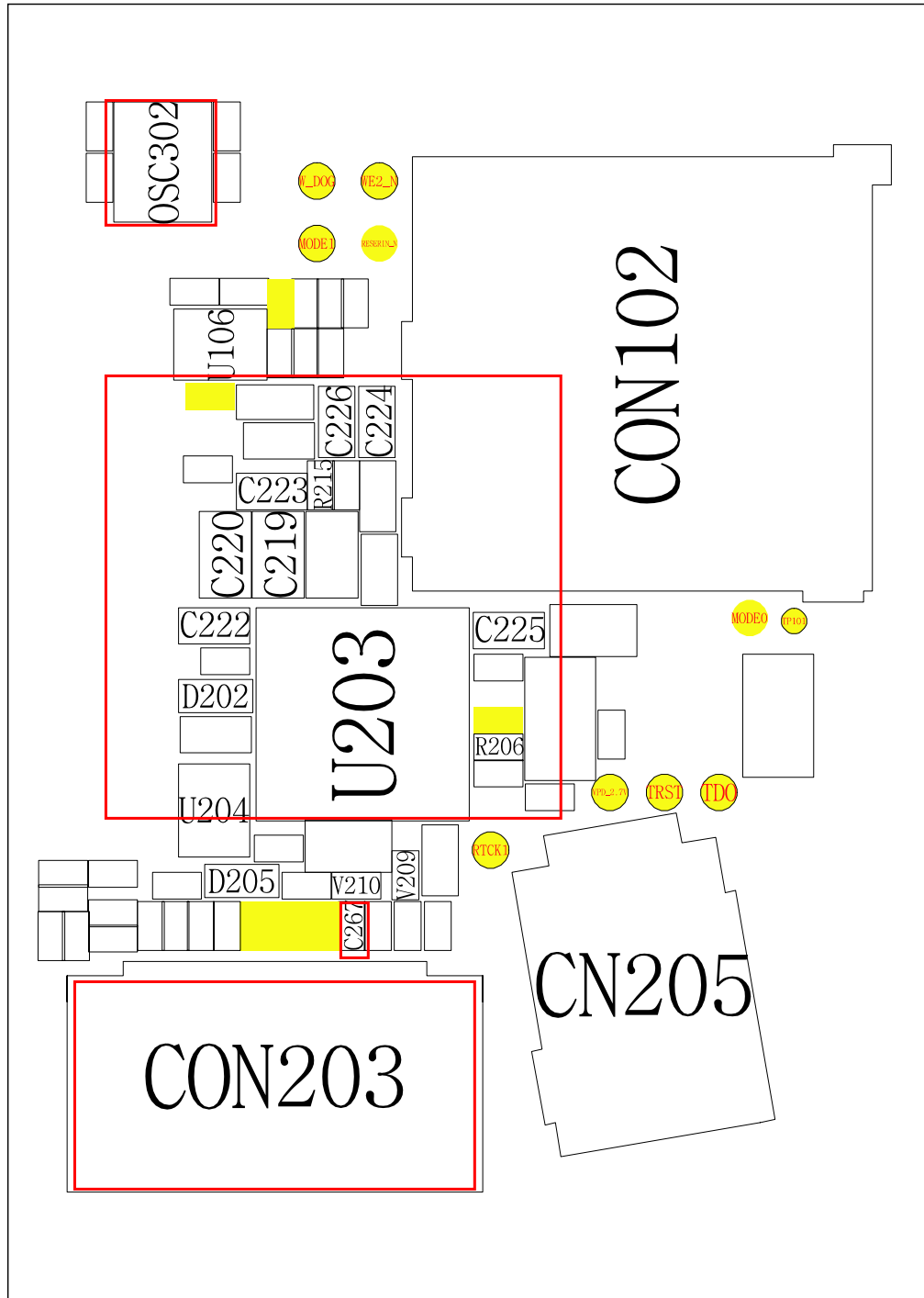

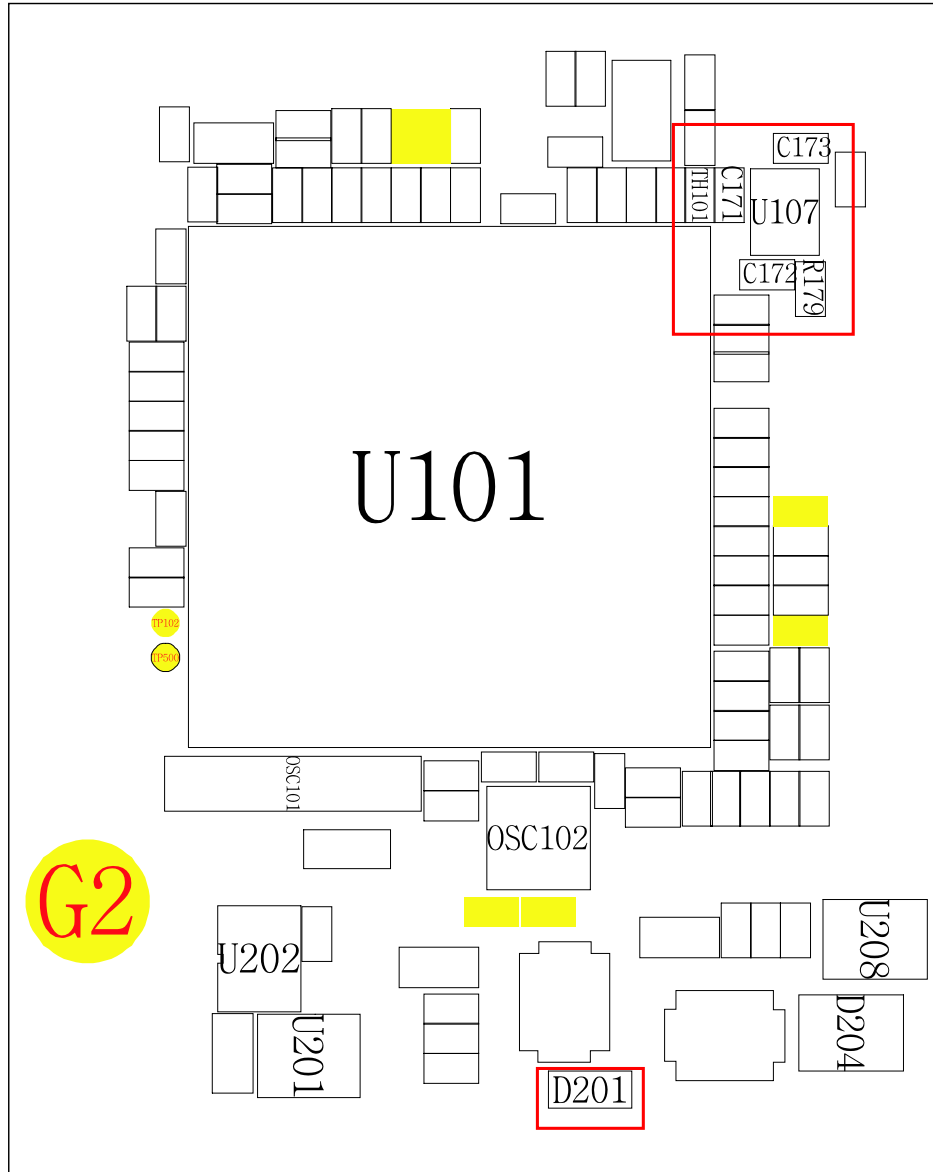

7-1-2 LCD Working

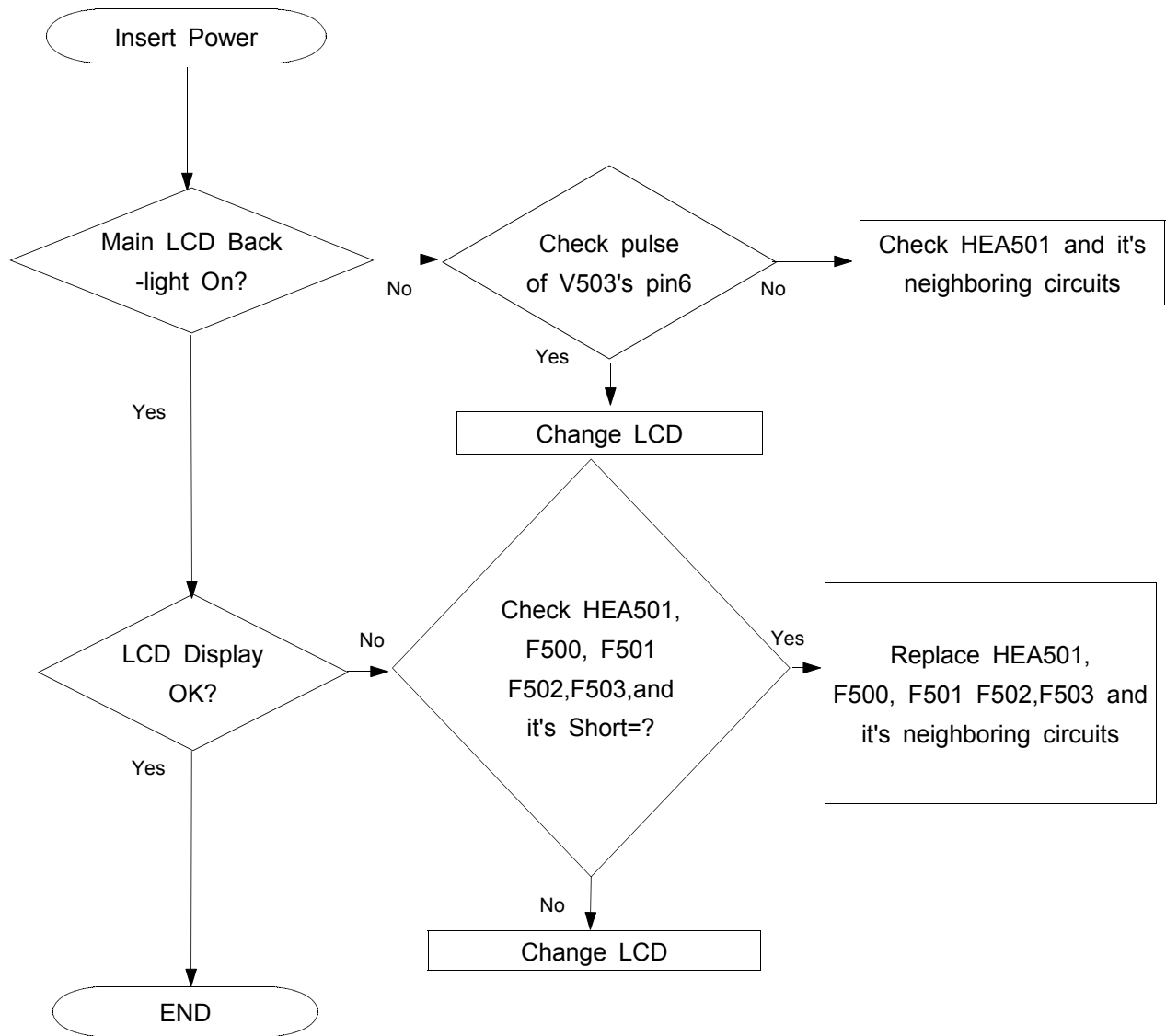

Flow Chart of Troubleshooting

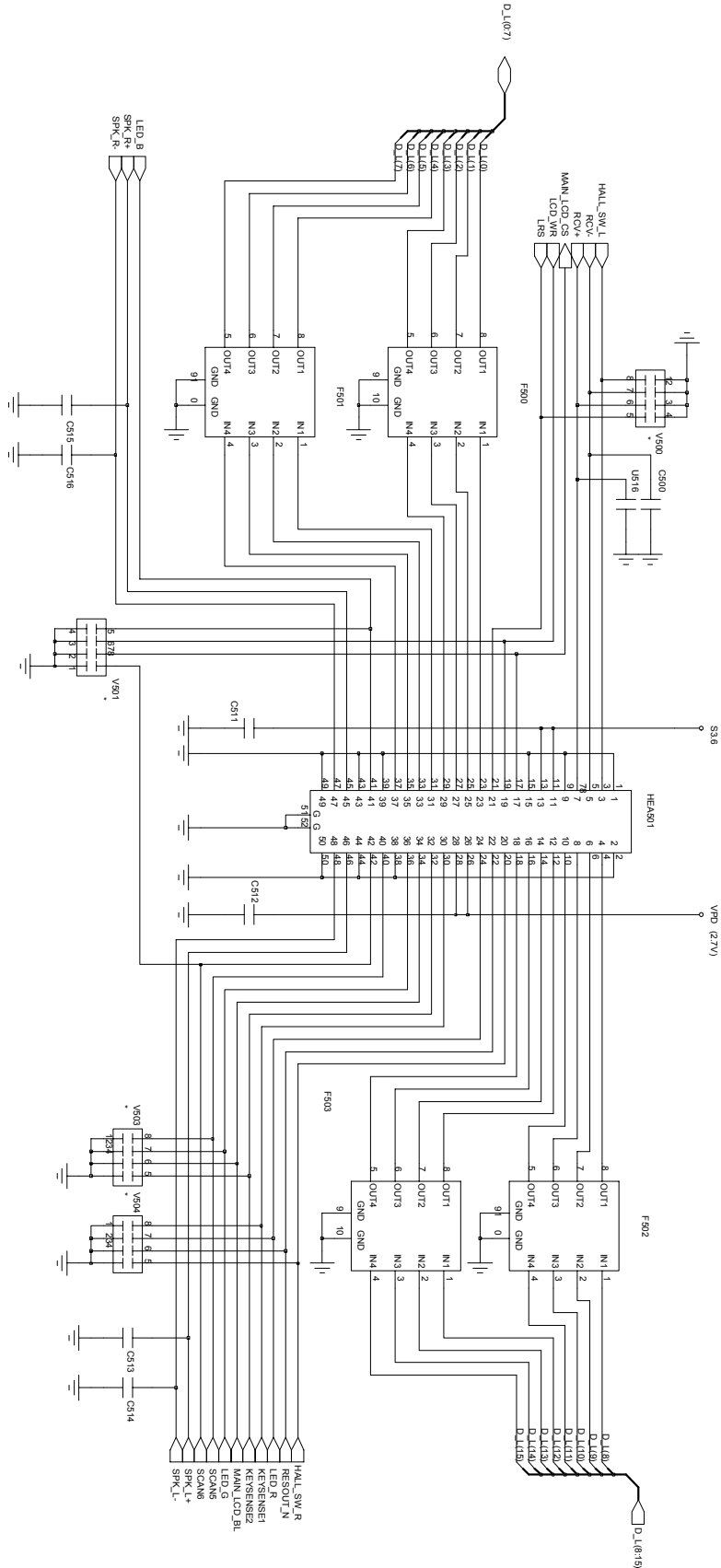

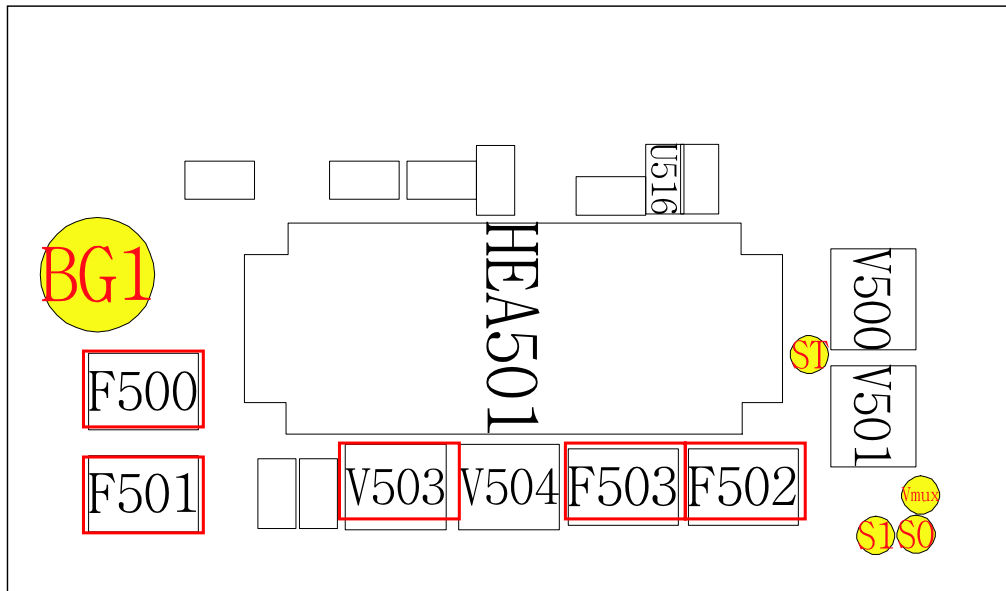

7-1-3 Speaker, Receiver and Mic Checking

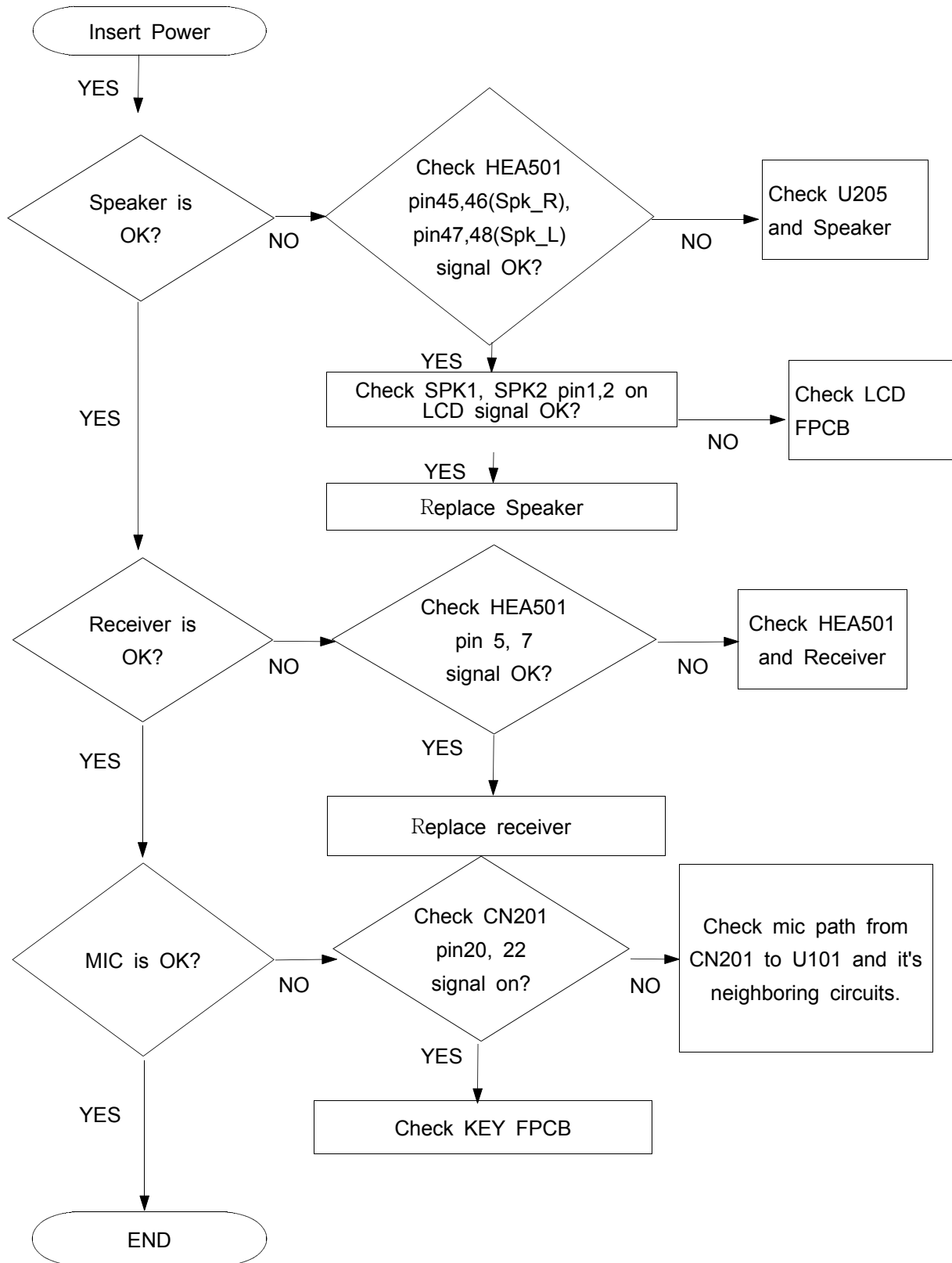

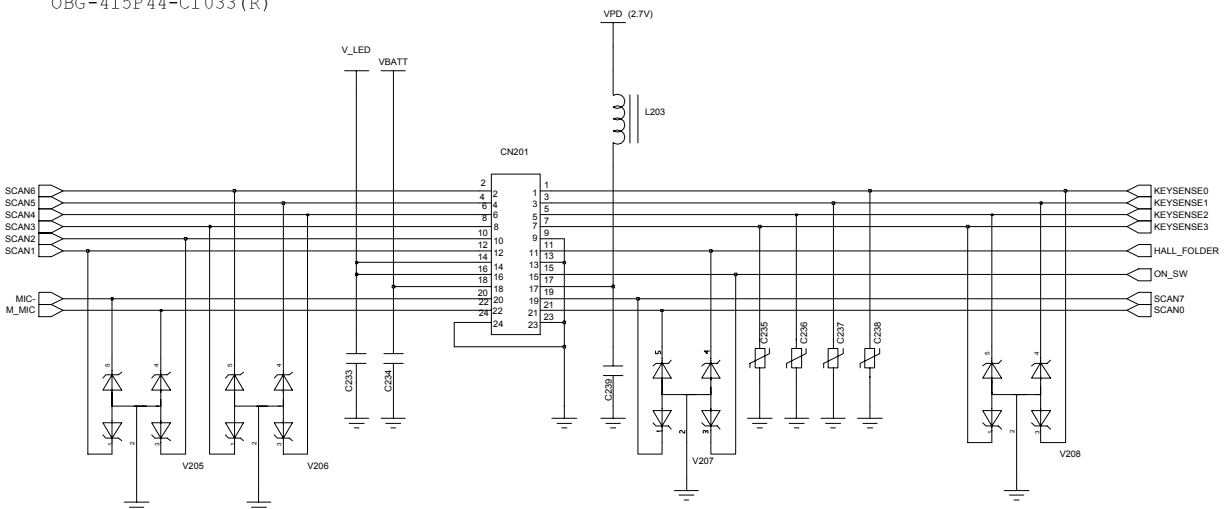
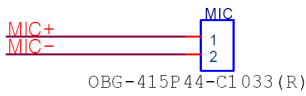
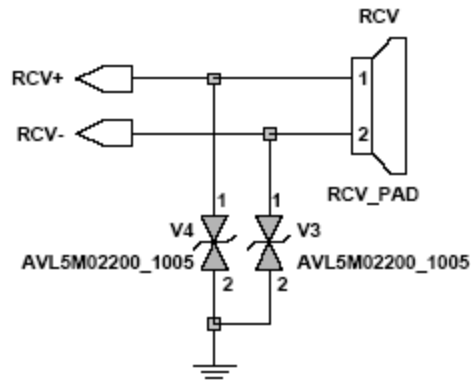
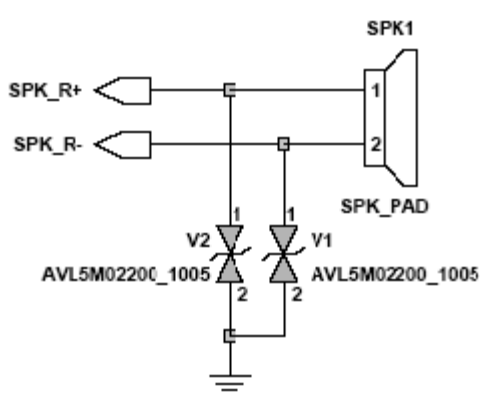
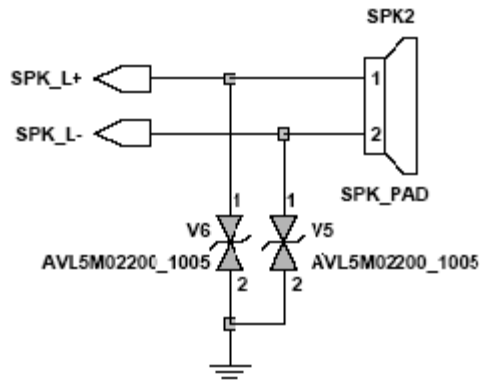

Flow Chart of Troubleshooting

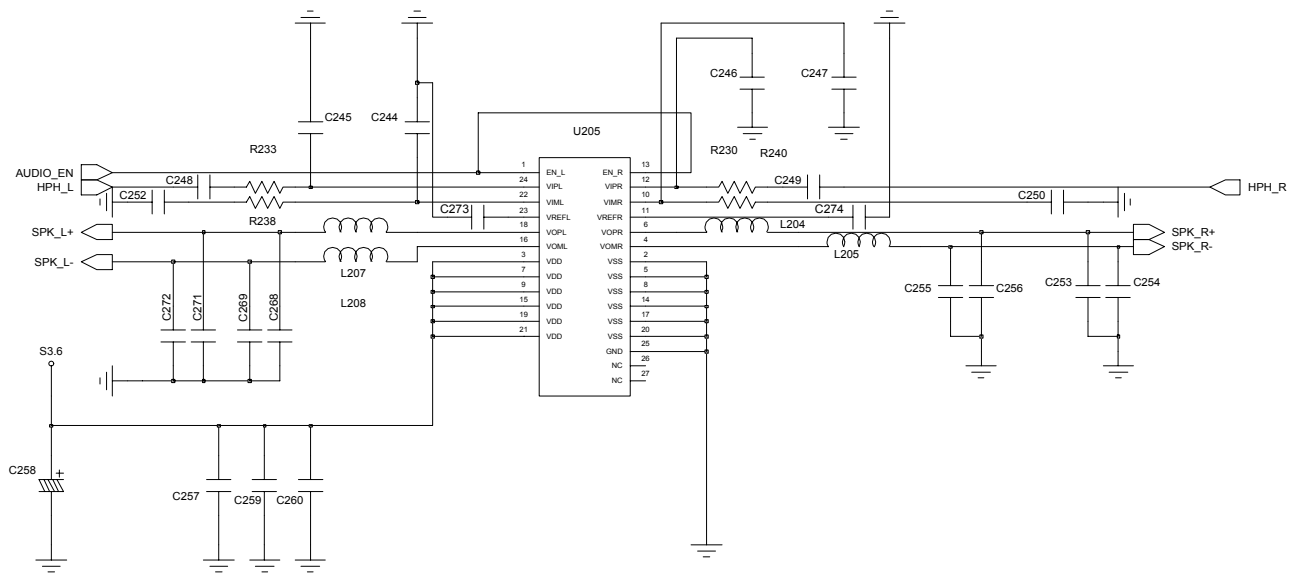

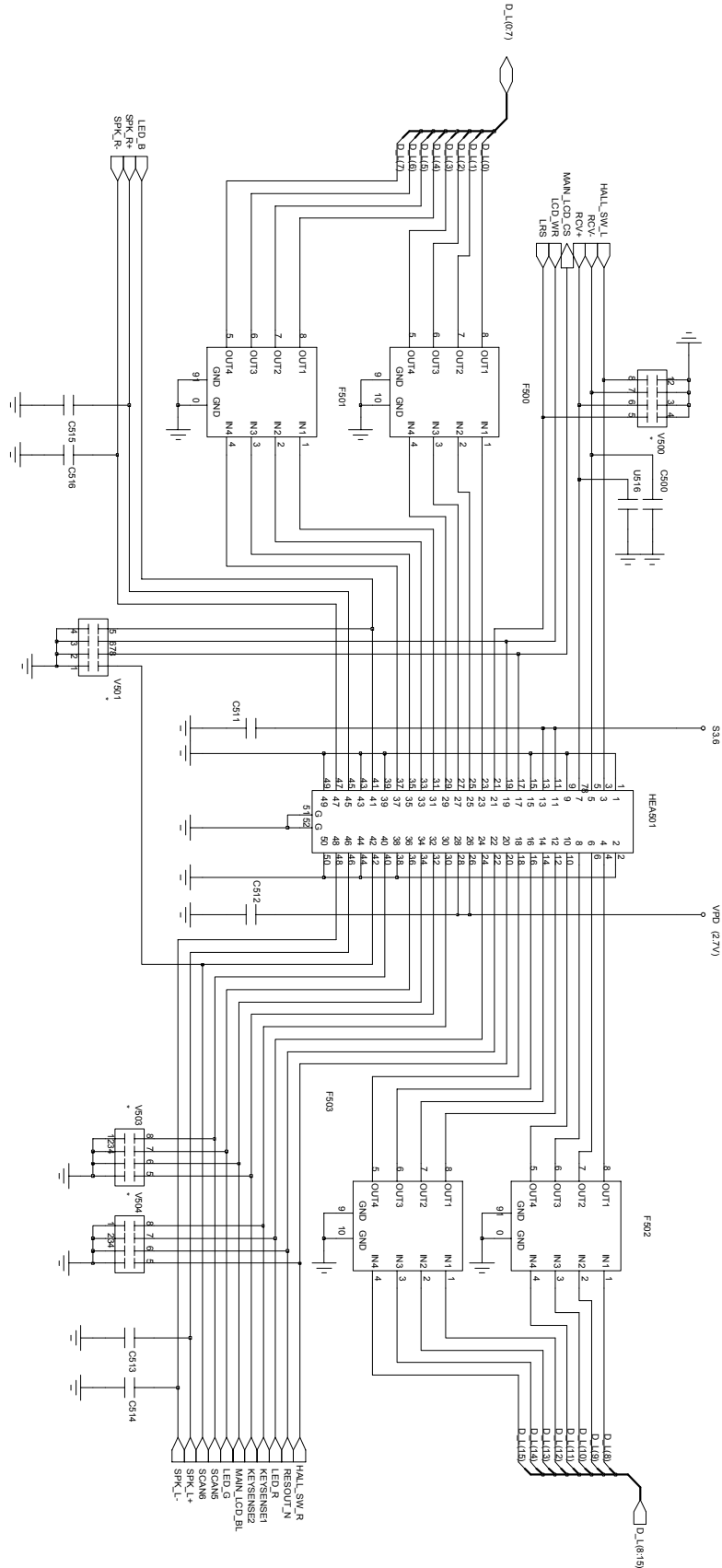

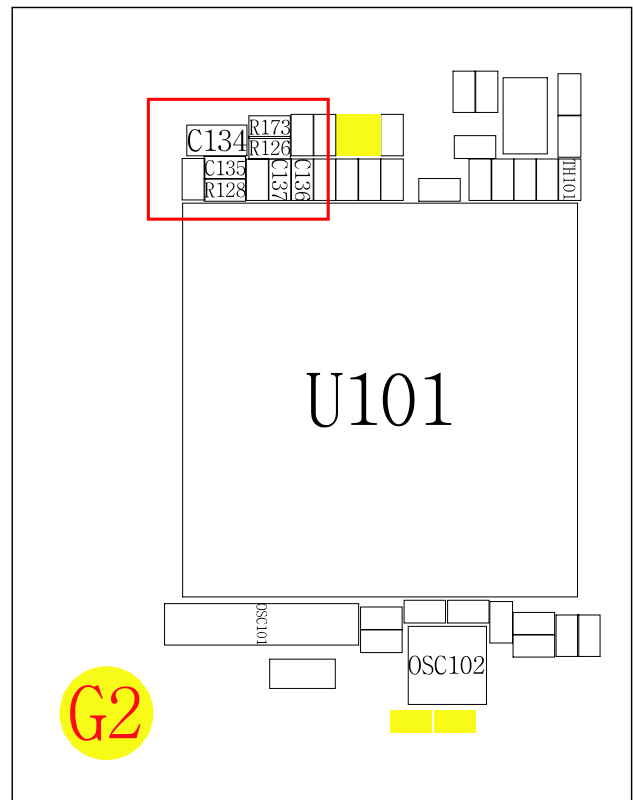
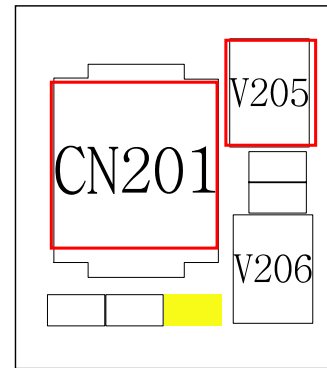
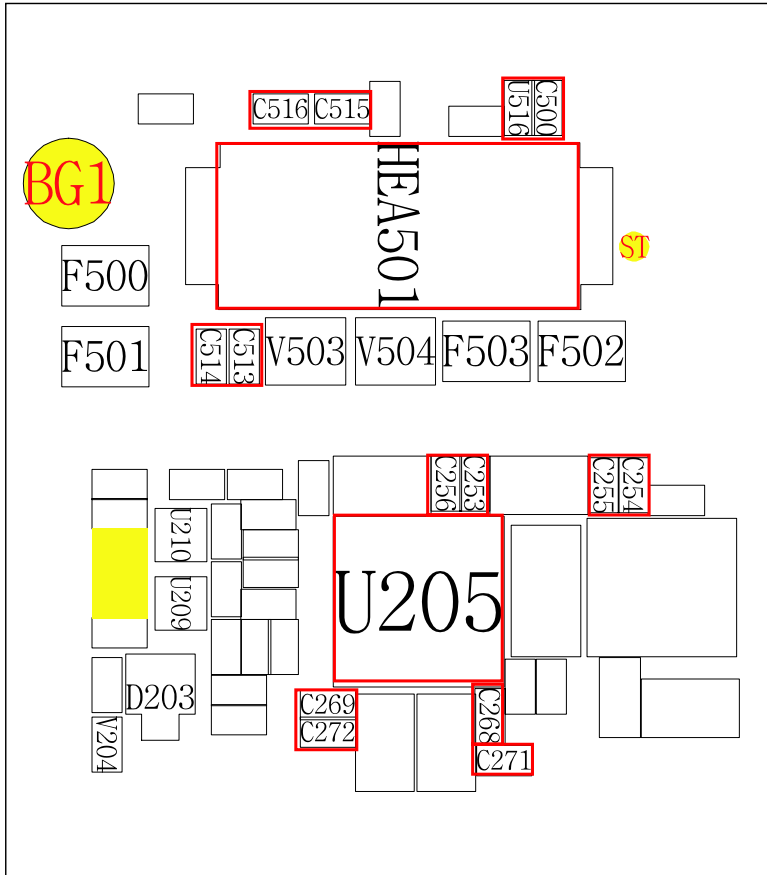

7-2. RX

7-2-1 CDMA/PCS mode

1. visual check! (soldering)
2. S/W Mode Check : CDMA Mode Check
3. OSC302 Check : 19.2MHz
4. VCO(OSC301) voltage/frequency level check
 Frequency : $1715\text{MHz} < f < 1788\text{MHz}$
 Supply Voltage: $2.75 \pm 0.1\text{V}$
 Control Voltage: $0.4 \sim 2.3\text{V}$
5. U301 LNA gain check
6. U403, U404 Check

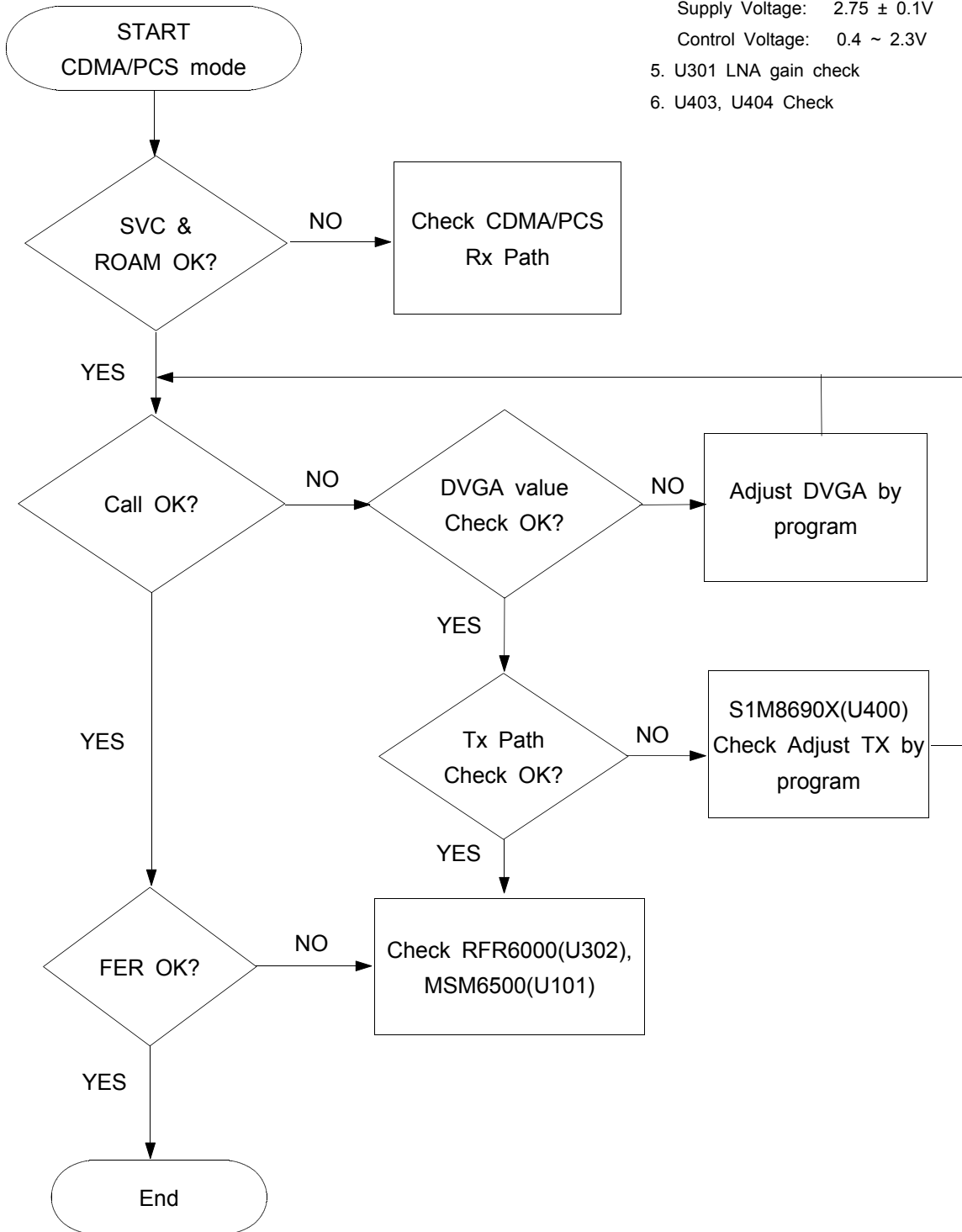

7-2-2 GPS Mode

- 1. visual check! (soldering)
- 2. S/W Test Mode Check : GPS Mode
- 3. OSC302 Check : 19.2MHz

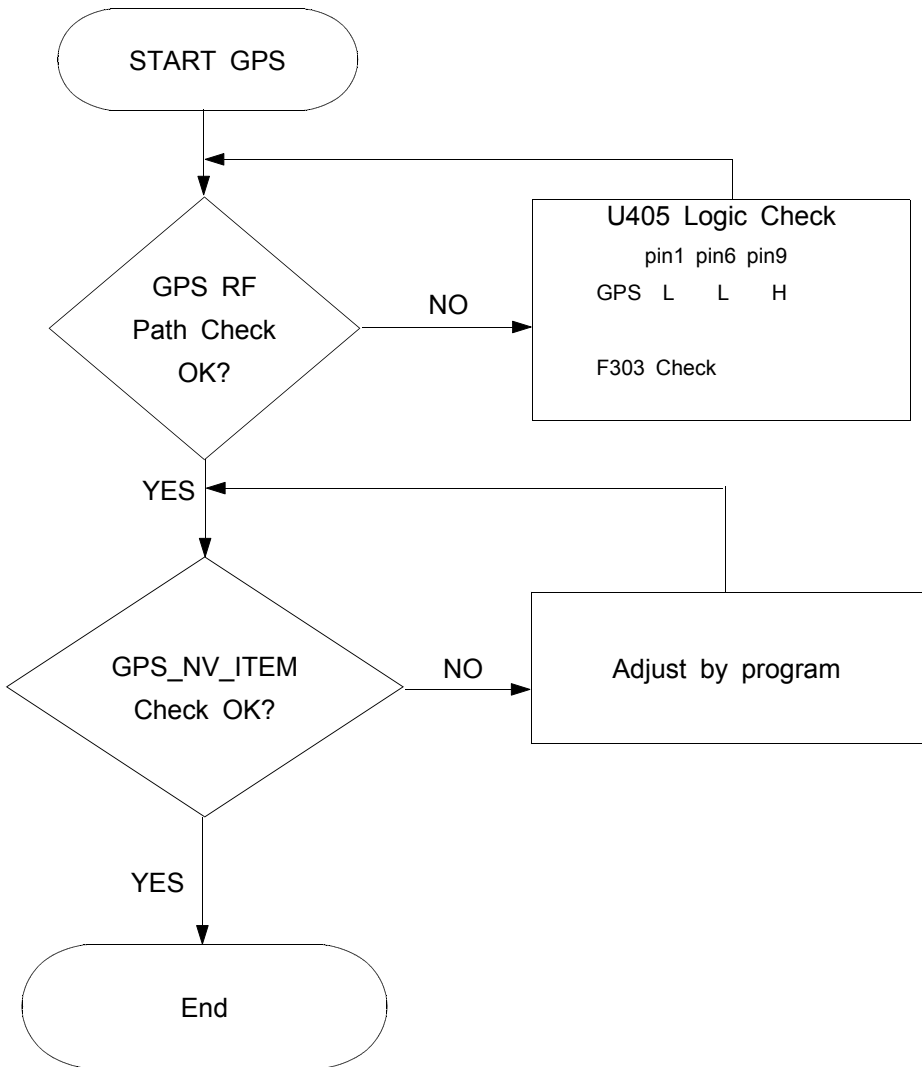

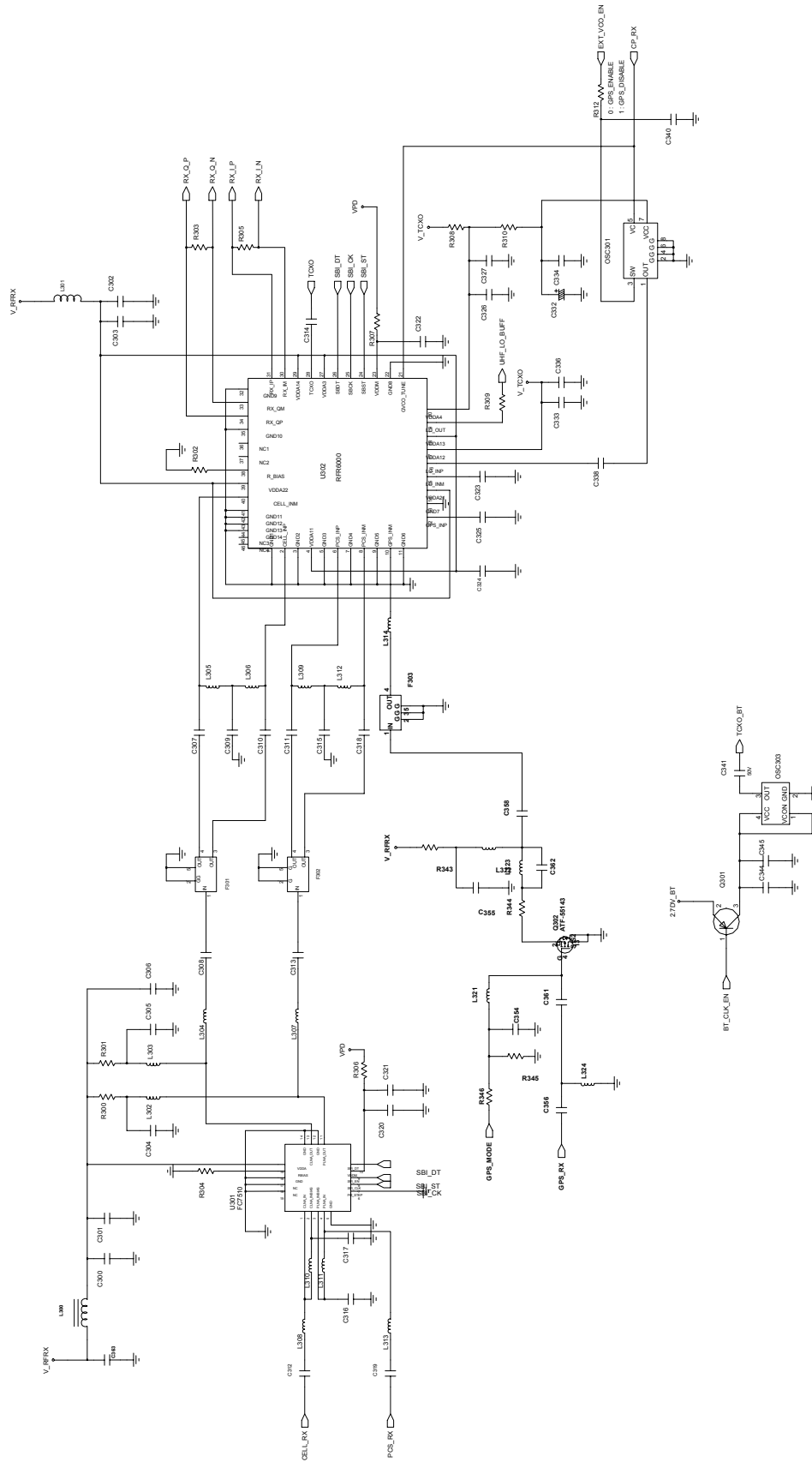

7-3 Tx

7-3-1 CDMA/PCS mode

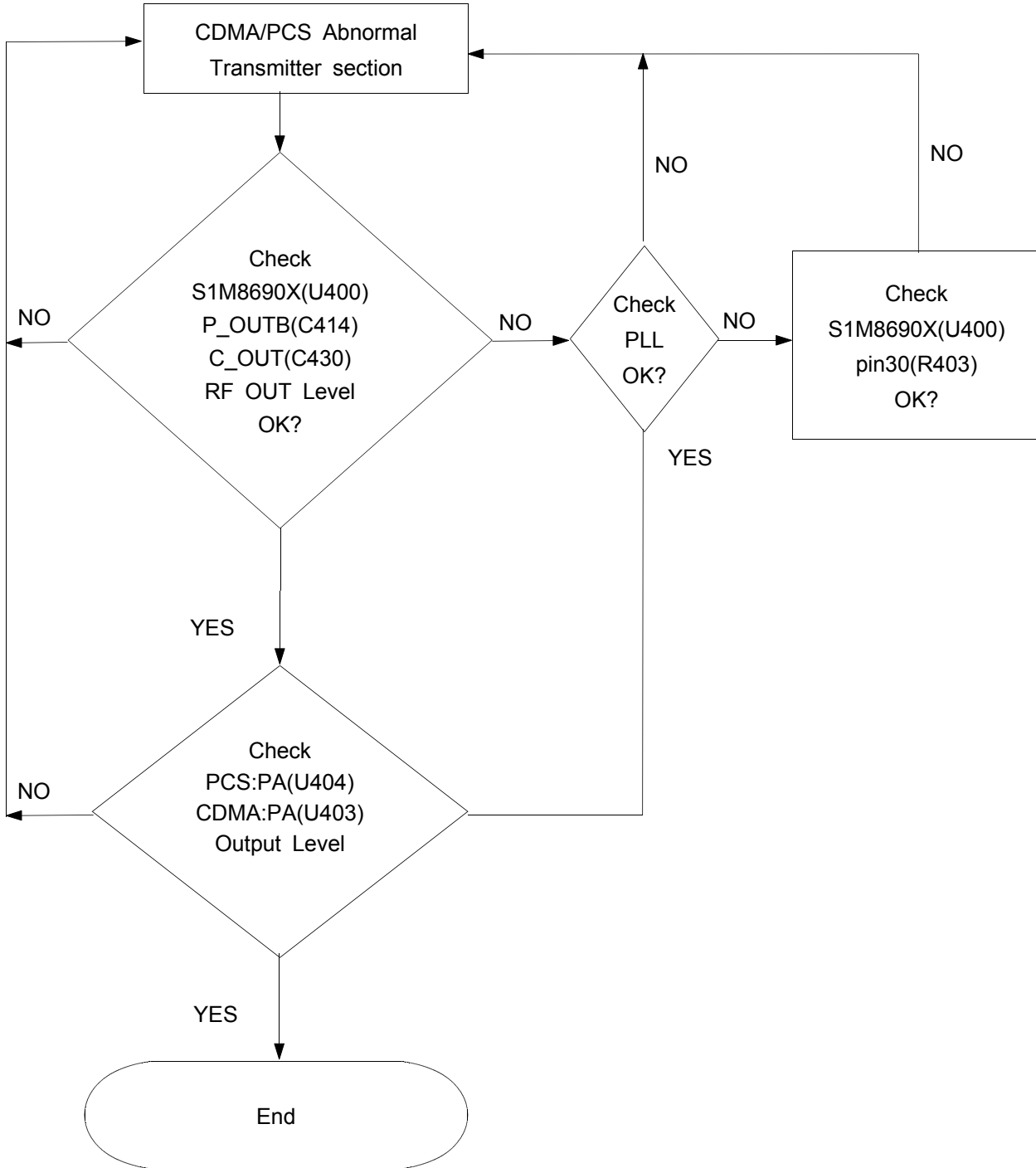

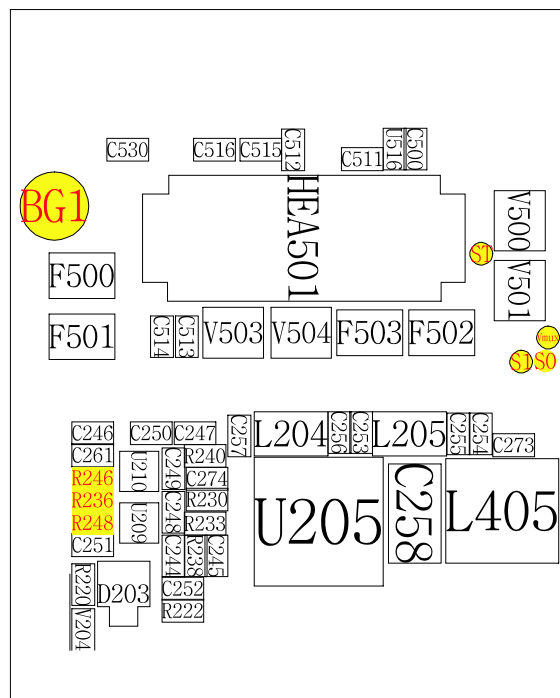
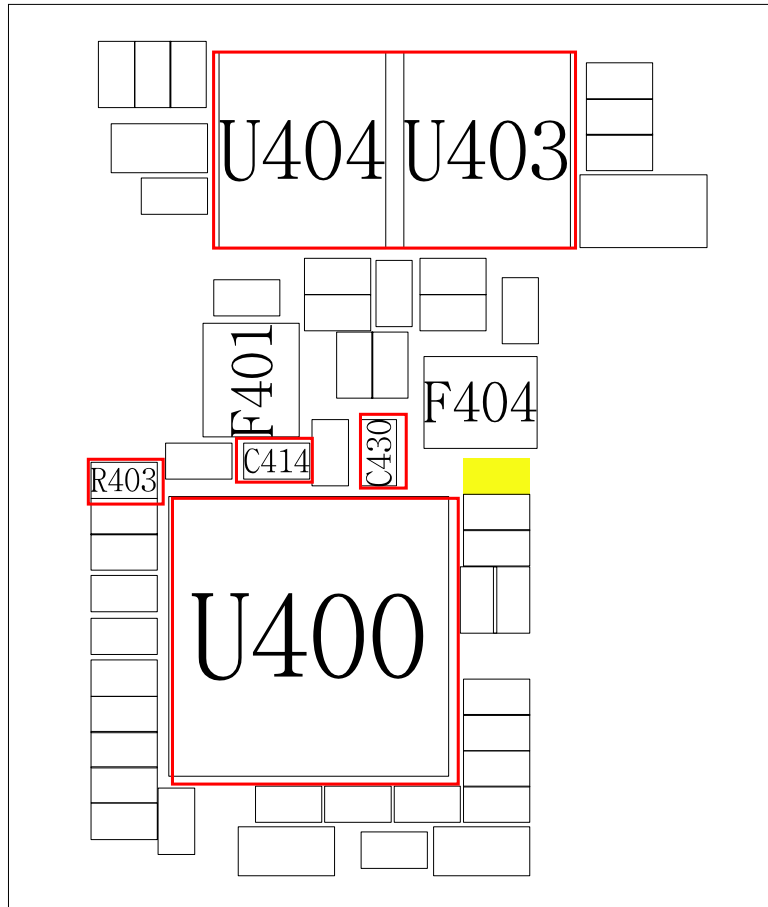

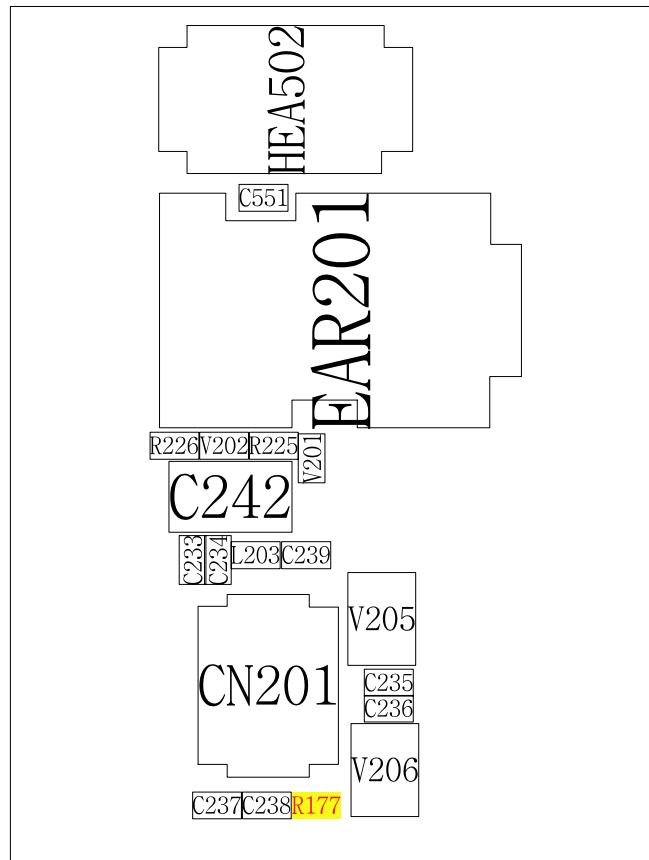
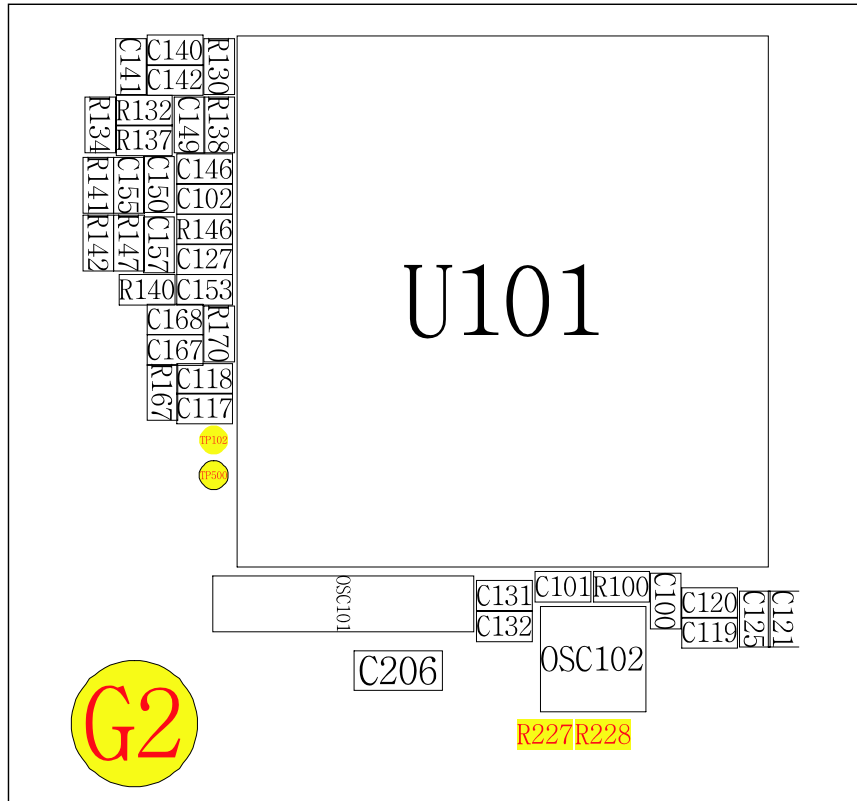

7-4 Camera checking

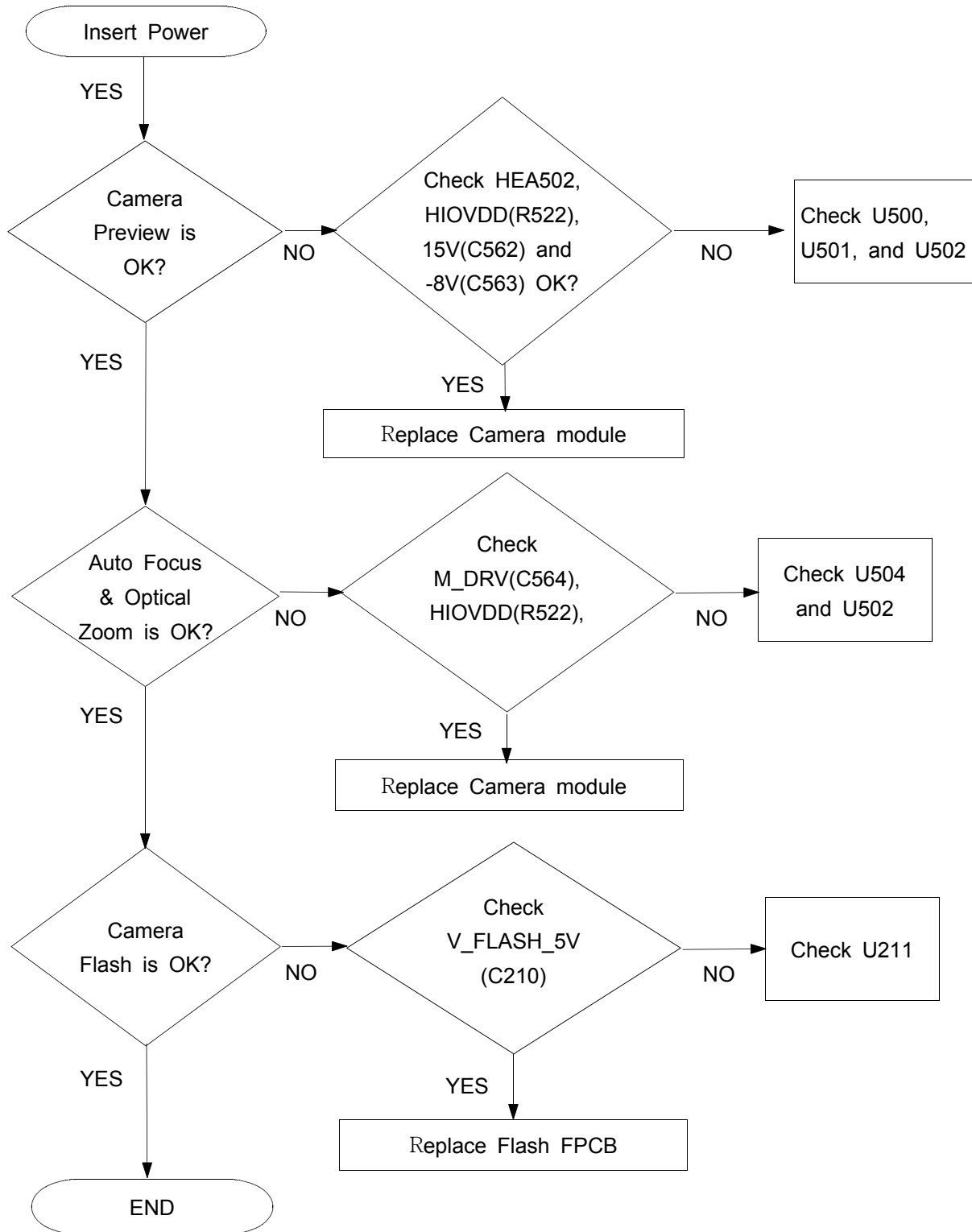

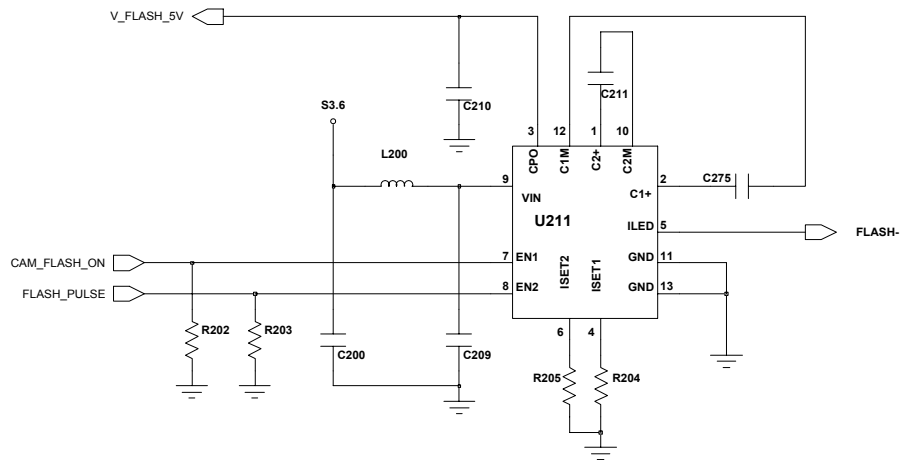

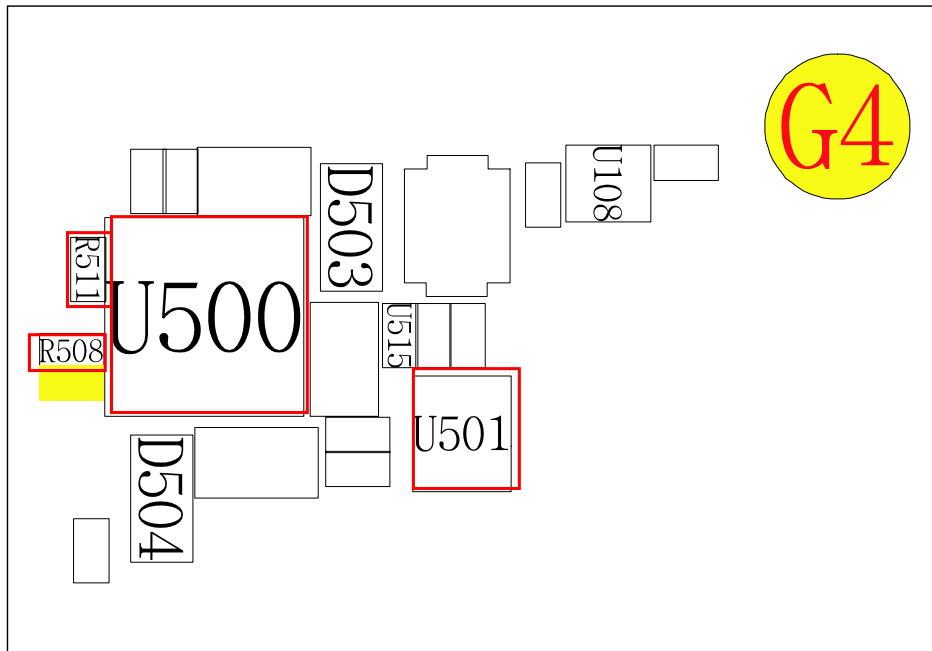
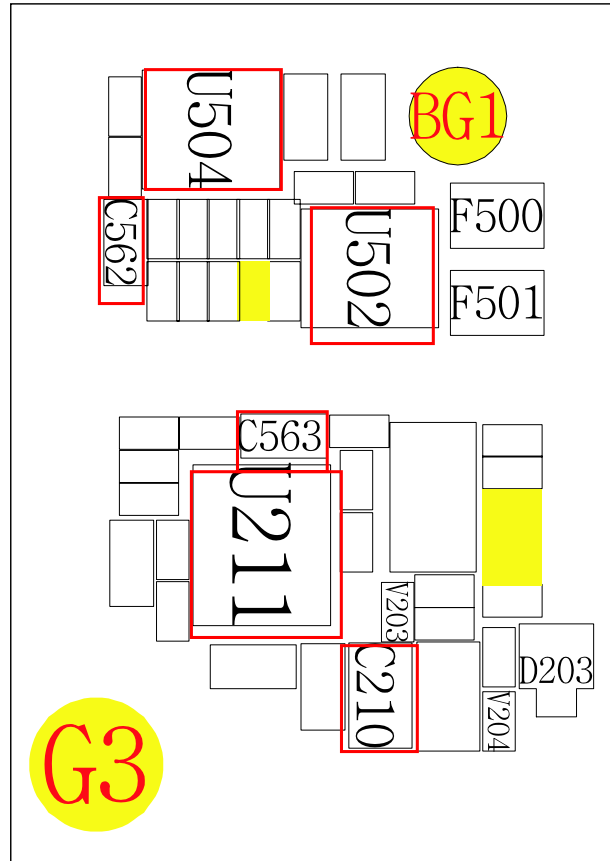
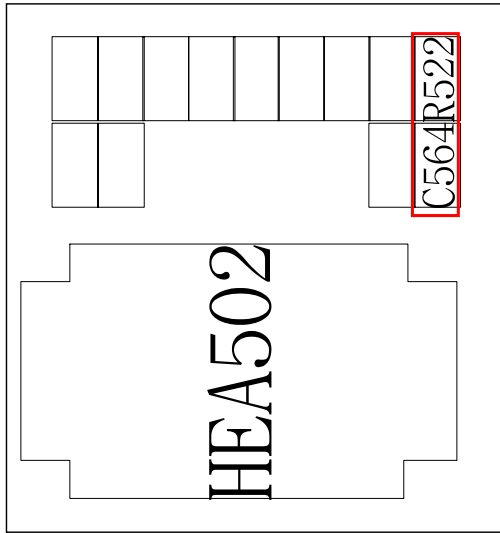

7-5 Bluetooth checking

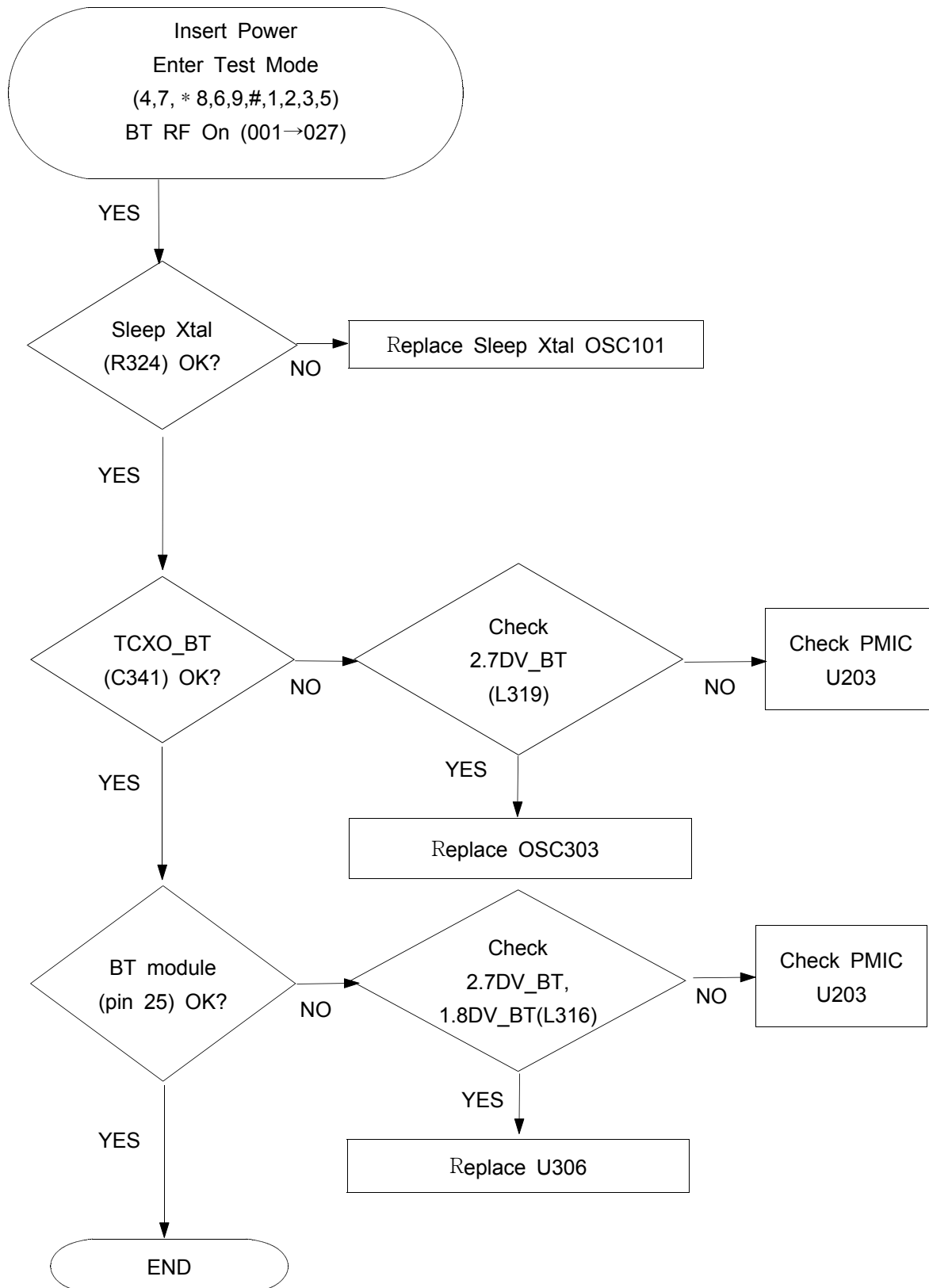

Flow Chart of Troubleshooting

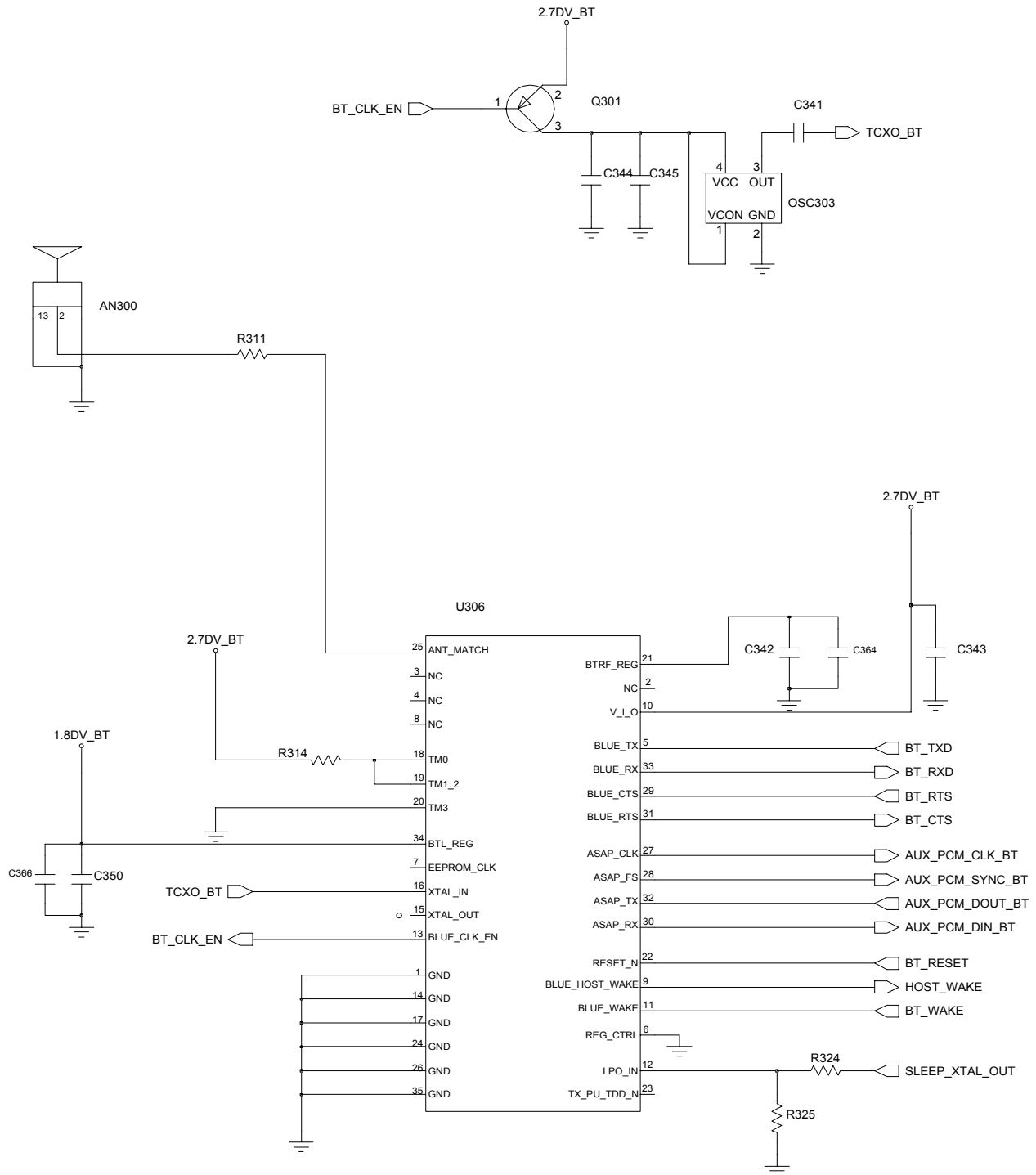

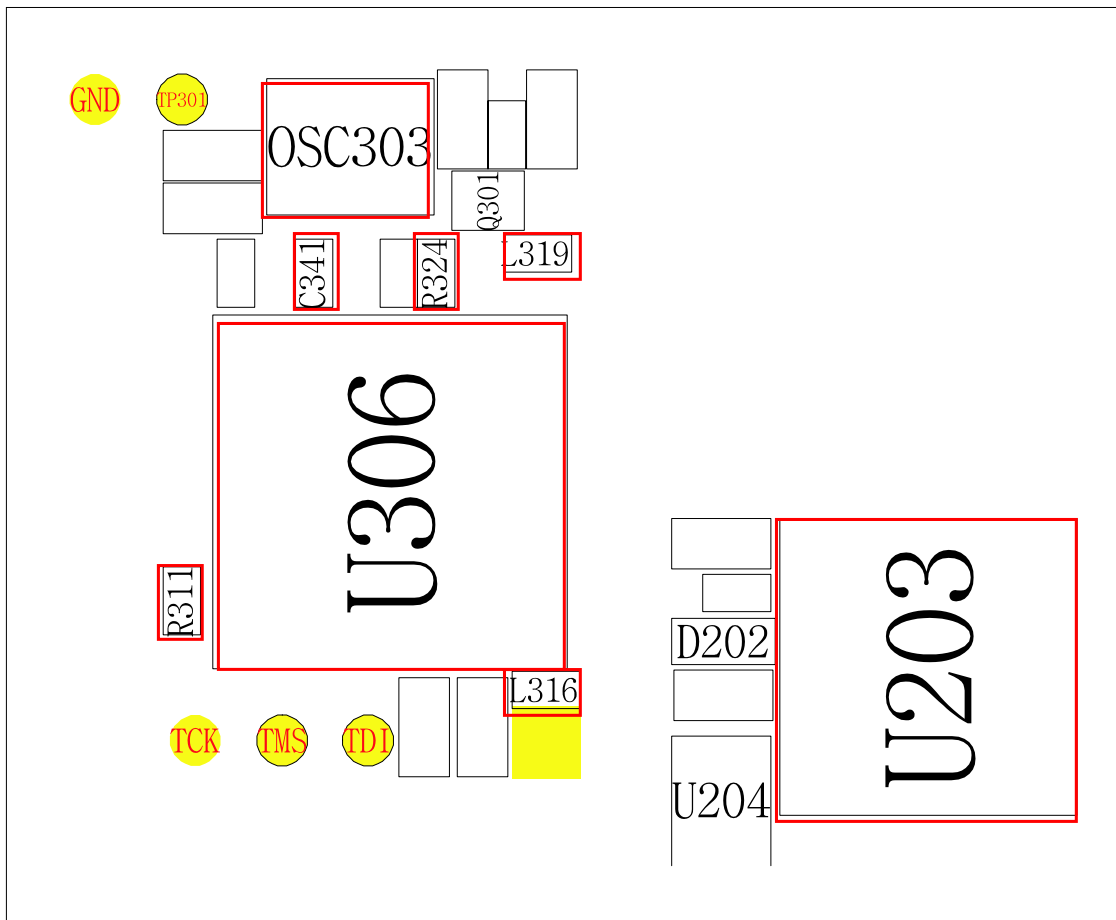
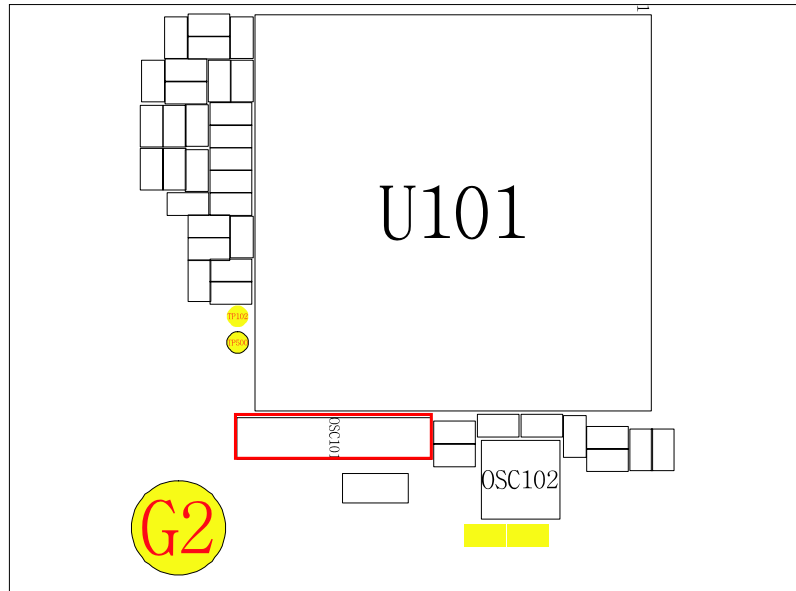

8. Exploded Views and Parts List

8-1. Exploded Views

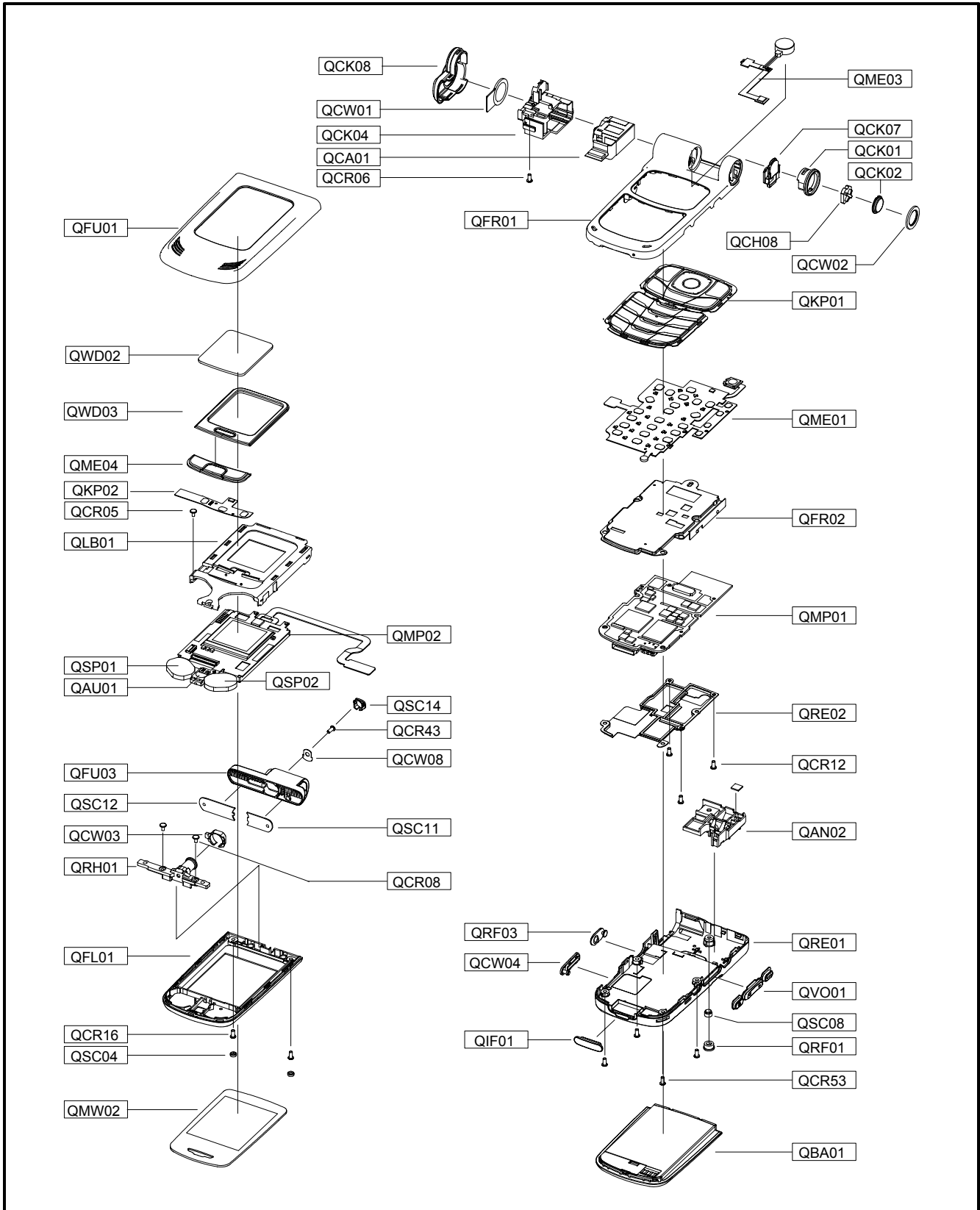

8-2. Parts List

Location No		Description	Sec Code
QAN02		ANTENNA-SPHA940	GH42-00659A
QAU01		AUDIO-RECEIVER	3009-001104
QBA01		BATTERY-1000MAH,SIL,ENG,M	GH43-02160A
QCA01		UNIT-CAMERA	GH59-01626A
QCH08		RMO-RUBBER KEY CAMERA	GH73-04179A
QCK01		MEC-CAMERA KEY DUMMY	GH75-06362A
QCK02		PMO-KEY CAMERA	GH72-19429A
QCK04		MEC-CAMERA BRACKET	GH75-07532A
QCK07		MEC-CAMERA KEY FIX	GH75-07513A
QCK08		MEC-CAMERA DUMMY	GH75-07979A
QCR05		SCREW-MACHINE	6001-001478
QCR06		SCREW-MACHINE	6001-001155
QCR12		SCREW-MACHINE	6001-001530
QCR16		SCREW-MACHINE	6001-001878
QCR43		SCREW-MACHINE	6001-001413
QCR53		SCREW-MACHINE	6001-001639
QCW01		PCT-CAMERA LENS	GH72-19798A
QCW02		PMO-CAMERA KEY DECO	GH72-23056A
QCW03		PMO-ROTARY RING	GH72-19156A
QCW08		ICT-ROTARY HINGE WASHER	GH70-00364A
QFR02		MEC-SHIELD CAN FRONT	GH75-06708A
QFU01		MEC-FOLDER UPPER	GH75-06350A
QFU03		MEC-FOLDER DUMMY	GH75-06353A
QKP01		MEC-KEYPAD MAIN	GH75-06355A
QKP02		MEC-KEY FOLD	GH75-06354A
QLB00		MEC-LCD BRACKET	GH75-06352A
QME01		UNIT-KEY FPCB	GH59-02401A
QME03		UNIT-FLASH FPCB	GH59-02399A
QME04		UNIT-MOD KEY	GH59-02400A
QMP01		PBA MAIN-SPHA940	GH92-02289A
QMP02		PBA ETC-LCD MODULE	GH92-02306A
QMW02		PCT-MAIN WINDOW	GH72-19431A
QRE02		MEC-SHIELD CAN REAR	GH75-06709A
QRF01		MPR-SHEET RF COVER	GH74-16885A
QSC04		RMO-F/LOWER SCREW CAP	GH73-04955A
QSC08		RMO-RUBBER R/SCREW CAP	GH73-05004A
QSC11		MPR-FOLDER DUMMY COVER R	GH74-16044A
QSC12		MPR-FOLDER DUMMY COVER L	GH74-16045A
QSC14		PMO-F/D HOLE COVER	GH72-19099A
QSP01		SPEAKER	3001-001817
QSP02		SPEAKER	3001-001816
QVO01		PMO-SIDE KEY	GH72-23246A
QWD02		PCT-SUB WINDOW	GH72-19432A
QWD03		PMO-DUAL WINDOW DECO	GH72-23251A
QRE01		MEC-REAR COVER	GH75-06349A
	QIF01	PMO-IF COVER	GH72-23249A
QFL01		MEC-FOLDER LOWER	GH75-07830A
	QCR08	SCREW-MACHINE	6001-001456
	QRH01	MEC-ROTARY HINGE	GH75-06361A
	QCW08	ICT-ROTARY HINGE WASHER	GH70-00364A
QFR01		MEC-FRONT COVER	GH75-06351A
	QRF03	PMO-EAR COVER	GH72-23362A
	QCW04	PMO-TFR COVER	GH72-19109A

Description	Sec Code
IC-MEMORY CARD	1109-001313
CONNECTOR-ADAPTOR	3719-001319
BAG PE	6902-000297
BAG PE	6902-000643
BAG ZIPPER	6902-000683
CBF SIGNAL-SPHA940 DANPLA	GH39-00466A
CHARGER-SCHA970 DTC	GH44-00909A
UNIT-EARPHONE	GH59-02008A
LABEL(P)-GUIDE(SPRINT)	GH68-02023A
LABEL(P)-WATER SOAK	GH68-02026A
LABEL(R)-MAIN(SPRINT)	GH68-06665A
MANUAL-SPRINT ACTIVATION	GH68-07877A
MANUAL-TERMS AND COMDITION	GH68-07930A
MANUAL-POWER VISION CARD	GH68-08092A
CUSHION-CASE	GH69-02740A
BOX(P)-UNIT(SPRINT)	GH69-02741A
PMO-SERVICE LED	GH72-19427A
RMO-RUBBER HOLDER VIBRAT	GH73-04231A
MPR-CONTACT VINYL	GH74-07554A
MPR-TAPE SUB WINDOW	GH74-12874A
MPR-TAPE LCD C	GH74-13240A
MPR-TAPE LCD A	GH74-15767A
MPR-GASKET CAM BRK	GH74-15982A
MPR-GASKET LCD CON	GH74-15983A
MPR-TAPE ROTARY SHAFT	GH74-15984A
MPR-TAPE MAIN PCB IF	GH74-15988A
MPR-TAPE MAIN KEY PCB TO	GH74-15989A
MPR-TAPE CAM FPCB	GH74-15990A
MPR-TAPE LCD CON 2	GH74-15991A
MPR-TAPE LCD CON 3	GH74-15992A
MPR-GASKET KEY FPCB	GH74-15995A
MPR-BOHO VINYL C/LENS A	GH74-16082A
MPR-BOHO VINYL C/LENS B	GH74-16083A
MPR-BOHO VINYL C/LENS C	GH74-16084A
MPR-BOHO VINYL F/UPPER A	GH74-16085A
MPR-BOHO VINYL F/UPPER B	GH74-16086A
MPR-BOHO VINYL F/LOWER A	GH74-16087A
MPR-BOHO VINYL F/LOWER B	GH74-16088A
MPR-BOHO VINYL F/U C	GH74-17102A
MPR-BOHO VINYL F/L C	GH74-17104A
MPR-TAPE MAIN SHIELD	GH74-17105A
MPR-TAPE KEY MOD FPCB	GH74-17168A
MPR-TAPE ZIP TYPE CON	GH74-17178A
MPR-BOHO VINYL CAM LENS D	GH74-17472A
PAA ETC-SPH A940(XAR)	GH99-11282A

8-3 DM Cable(GH39-00129A)



8-4 Test JIG



8-5 RF Cable(GH39-00397A)



8-6 Test Jig Cable(GH39-00399A)



9. Block Diagram

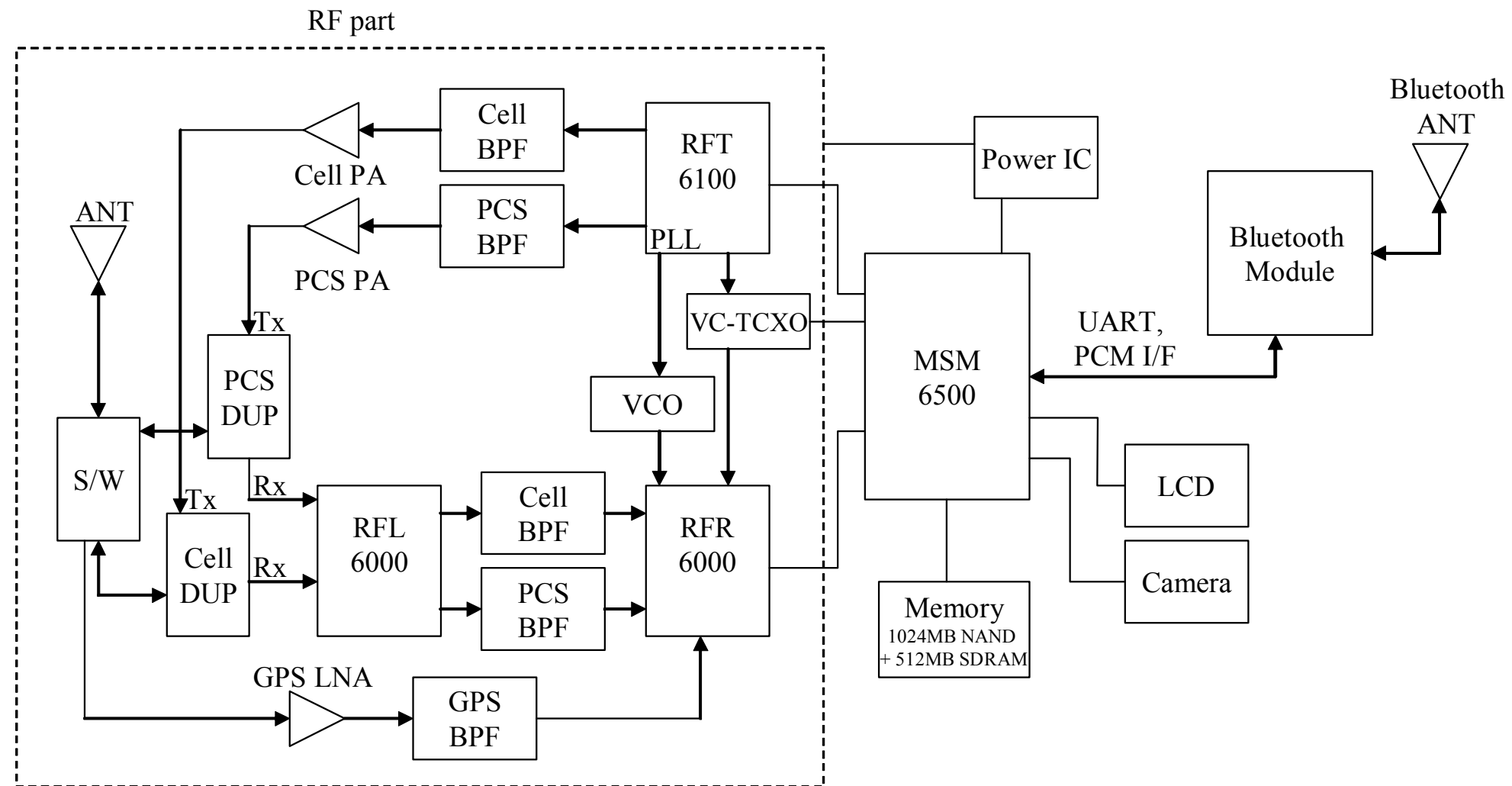

10. Electrical Parts List

Design LOC	Description	SEC CODE	STATUS
AN300	ANTENNA-CHIP	4202-001065	SA
C100	C-CER,CHIP	2203-005393	SA
C101	C-CER,CHIP	2203-005393	SA
C102	C-CER,CHIP	2203-000812	SA
C103	C-CER,CHIP	2203-000812	SA
C104	C-CER,CHIP	2203-005061	SA
C105	C-CER,CHIP	2203-006093	SA
C106	C-CER,CHIP	2203-005061	SA
C107	C-CER,CHIP	2203-000254	SA
C108	C-CER,CHIP	2203-005061	SA
C109	C-CER,CHIP	2203-000254	SA
C110	C-CER,CHIP	2203-005061	SA
C111	C-CER,CHIP	2203-000254	SA
C112	C-CER,CHIP	2203-005061	SA
C113	C-CER,CHIP	2203-000254	SA
C114	C-CER,CHIP	2203-005061	SA
C116	C-CER,CHIP	2203-001072	SA
C117	C-CER,CHIP	2203-000254	SA
C118	C-CER,CHIP	2203-005061	SA
C119	C-CER,CHIP	2203-000254	SA
C12	C-CER,CHIP	2203-006399	SA
C120	C-CER,CHIP	2203-005061	SA
C121	C-CER,CHIP	2203-000233	SA
C123	C-CER,CHIP	2203-000254	SA
C124	C-CER,CHIP	2203-000254	SA
C125	C-CER,CHIP	2203-000254	SA
C126	C-CER,CHIP	2203-000254	SA
C127	C-CER,CHIP	2203-005061	SA
C13	C-CER,CHIP	2203-006399	SA
C131	C-CER,CHIP	2203-000679	SA
C132	C-CER,CHIP	2203-000679	SA
C133	C-CER,CHIP	2203-006093	SA
C134	C-CER,CHIP	2203-006053	SA
C135	C-CER,CHIP	2203-005482	SA
C136	C-CER,CHIP	2203-001405	SA
C137	C-CER,CHIP	2203-001405	SA
C138	C-CER,CHIP	2203-001405	SA
C139	C-CER,CHIP	2203-001405	SA
C14	C-CER,CHIP	2203-006399	SA
C140	C-CER,CHIP	2203-005061	SA
C141	C-CER,CHIP	2203-005061	SA
C142	C-CER,CHIP	2203-006091	SA
C143	C-CER,CHIP	2203-000812	SA
C144	C-CER,CHIP	2203-000812	SA
C145	C-CER,CHIP	2203-000812	SA
C146	C-CER,CHIP	2203-006091	SA
C147	C-CER,CHIP	2203-005061	SA
C149	C-CER,CHIP	2203-005061	SA
C15	C-CER,CHIP	2203-005065	SA
C150	C-CER,CHIP	2203-005061	SA

Electrical Parts List

Design LOC	Description	SEC CODE	STATUS
C152	C-CER,CHIP	2203-005061	SA
C153	C-CER,CHIP	2203-005061	SA
C154	C-CER,CHIP	2203-005061	SA
C155	C-CER,CHIP	2203-005061	SA
C157	C-CER,CHIP	2203-000233	SA
C159	C-CER,CHIP	2203-000254	SA
C16	C-CER,CHIP	2203-005061	SA
C160	C-CER,CHIP	2203-000254	SA
C161	C-CER,CHIP	2203-005509	SA
C162	C-CER,CHIP	2203-000254	SA
C163	C-CER,CHIP	2203-001432	SA
C164	C-CER,CHIP	2203-001432	SA
C165	C-CER,CHIP	2203-001432	SA
C166	C-CER,CHIP	2203-005482	SA
C167	C-CER,CHIP	2203-005509	SA
C168	C-CER,CHIP	2203-000885	SA
C169	C-CER,CHIP	2203-000254	SA
C17	C-CER,CHIP	2203-005061	SA
C170	C-CER,CHIP	2203-005061	SA
C171	C-CER,CHIP	2203-005061	SA
C172	C-CER,CHIP	2203-000995	SA
C173	C-CER,CHIP	2203-000254	SA
C174	C-CER,CHIP	2203-006093	SA
C175	C-CER,CHIP	2203-006093	SA
C18	C-CER,CHIP	2203-005061	SA
C19	C-CER,CHIP	2203-005061	SA
C20	C-CER,CHIP	2203-000995	SA
C200	C-CER,CHIP	2203-005482	SA
C201	C-CER,CHIP	2203-006329	SA
C202	C-TA,CHIP	2404-001274	SA
C203	C-CER,CHIP	2203-000254	SA
C204	C-CER,CHIP	2203-006348	SA
C205	C-CER,CHIP	2203-005061	SA
C206	C-TA,CHIP	2404-001381	SA
C207	C-TA,CHIP	2404-001274	SA
C208	C-CER,CHIP	2203-006324	SA
C209	C-CER,CHIP	2203-006201	SA
C21	C-CER,CHIP	2203-000995	SA
C210	C-CER,CHIP	2203-006329	SA
C211	C-CER,CHIP	2203-006324	SA
C212	C-CER,CHIP	2203-000254	SA
C213	C-CER,CHIP	2203-001652	SA
C214	C-CER,CHIP	2203-000585	SA
C215	C-CER,CHIP	2203-006201	SA
C216	C-CER,CHIP	2203-000585	SA
C217	C-CER,CHIP	2203-006201	SA
C218	C-CER,CHIP	2203-000438	SA
C219	C-CER,CHIP	2203-005664	SA
C22	C-CER,CHIP	2203-000995	SA
C220	C-CER,CHIP	2203-005664	SA

Design LOC	Description	SEC CODE	STATUS
C221	C-TA,CHIP	2404-001105	SA
C222	C-CER,CHIP	2203-006201	SA
C223	C-CER,CHIP	2203-006201	SA
C224	C-CER,CHIP	2203-006053	SA
C225	C-CER,CHIP	2203-006053	SA
C226	C-CER,CHIP	2203-006201	SA
C227	C-CER,CHIP	2203-006324	SA
C228	C-CER,CHIP	2203-006324	SA
C229	C-CER,CHIP	2203-005061	SA
C23	C-TA,CHIP	2404-001225	SA
C230	C-CER,CHIP	2203-005061	SA
C231	C-CER,CHIP	2203-005061	SA
C233	C-CER,CHIP	2203-005482	SA
C234	C-CER,CHIP	2203-005482	SA
C235	VARISTOR	1405-001110	SA
C236	VARISTOR	1405-001138	SA
C237	VARISTOR	1405-001138	SA
C238	VARISTOR	1405-001138	SA
C239	C-CER,CHIP	2203-005482	SA
C240	C-CER,CHIP	2203-006053	SA
C241	C-TA,CHIP	2404-001305	SA
C242	C-TA,CHIP	2404-001305	SA
C243	C-CER,CHIP	2203-000812	SA
C244	C-CER,CHIP	2203-000233	SA
C245	C-CER,CHIP	2203-000233	SA
C246	C-CER,CHIP	2203-000233	SA
C247	C-CER,CHIP	2203-000233	SA
C248	C-CER,CHIP	2203-005480	SA
C249	C-CER,CHIP	2203-005480	SA
C250	C-CER,CHIP	2203-005480	SA
C251	C-CER,CHIP	2203-005482	SA
C252	C-CER,CHIP	2203-005480	SA
C253	C-CER,CHIP	2203-000812	SA
C254	C-CER,CHIP	2203-000812	SA
C255	C-CER,CHIP	2203-000438	SA
C256	C-CER,CHIP	2203-000438	SA
C257	C-CER,CHIP	2203-005482	SA
C258	C-TA,CHIP	2404-001347	SA
C259	C-CER,CHIP	2203-005061	SA
C260	C-CER,CHIP	2203-005061	SA
C261	C-CER,CHIP	2203-005482	SA
C262	C-CER,CHIP	2203-000940	SA
C263	C-CER,CHIP	2203-000233	SA
C264	C-CER,CHIP	2203-000438	SA
C265	C-CER,CHIP	2203-005061	SA
C266	C-CER,CHIP	2203-000254	SA
C267	C-CER,CHIP	2203-000812	SA
C268	C-CER,CHIP	2203-000438	SA
C269	C-CER,CHIP	2203-000438	SA
C270	C-TA,CHIP	2404-001381	SA

Electrical Parts List

Design LOC	Description	SEC CODE	STATUS
C271	C-CER,CHIP	2203-000812	SA
C272	C-CER,CHIP	2203-000812	SA
C273	C-CER,CHIP	2203-006093	SA
C274	C-CER,CHIP	2203-006093	SA
C275	C-CER,CHIP	2203-006324	SA
C276	C-CER,CHIP	2203-006090	SA
C277	C-CER,CHIP	2203-006090	SA
C300	C-CER,CHIP	2203-006201	SA
C301	C-CER,CHIP	2203-000233	SA
C302	C-CER,CHIP	2203-006201	SA
C303	C-CER,CHIP	2203-000995	SA
C306	C-CER,CHIP	2203-000233	SA
C307	C-CER,CHIP	2203-001017	SA
C308	C-CER,CHIP	2203-000438	SA
C309	C-CER,CHIP	2203-005061	SA
C310	C-CER,CHIP	2203-001017	SA
C311	C-CER,CHIP	2203-005446	SA
C312	C-CER,CHIP	2203-000438	SA
C313	C-CER,CHIP	2203-000438	SA
C314	C-CER,CHIP	2203-000438	SA
C315	C-CER,CHIP	2203-005061	SA
C318	C-CER,CHIP	2203-005446	SA
C319	C-CER,CHIP	2203-000438	SA
C320	C-CER,CHIP	2203-005482	SA
C321	C-CER,CHIP	2203-000233	SA
C322	C-CER,CHIP	2203-005061	SA
C323	C-CER,CHIP	2203-000995	SA
C324	C-CER,CHIP	2203-006093	SA
C325	C-CER,CHIP	2203-000233	SA
C326	C-CER,CHIP	2203-005061	SA
C327	C-CER,CHIP	2203-000995	SA
C332	C-TA,CHIP	2404-001381	SA
C333	C-CER,CHIP	2203-005061	SA
C334	C-CER,CHIP	2203-005482	SA
C336	C-CER,CHIP	2203-000995	SA
C338	C-CER,CHIP	2203-000995	SA
C340	C-CER,CHIP	2203-005061	SA
C341	C-CER,CHIP	2203-000438	SA
C342	C-CER,CHIP	2203-006201	SA
C343	C-CER,CHIP	2203-006053	SA
C344	C-CER,CHIP	2203-005065	SA
C345	C-CER,CHIP	2203-000438	SA
C346	C-CER,CHIP	2203-006093	SA
C347	C-CER,CHIP	2203-005482	SA
C348	C-CER,CHIP	2203-000233	SA
C349	C-CER,CHIP	2203-000254	SA
C350	C-CER,CHIP	2203-006201	SA
C354	C-CER,CHIP	2203-000438	SA
C355	C-CER,CHIP	2203-005050	SA
C356	C-CER,CHIP	2203-000233	SA

Design LOC	Description	SEC CODE	STATUS
C358	C-CER,CHIP	2203-000870	SA
C361	C-CER,CHIP	2203-000233	SA
C363	C-CER,CHIP	2203-006093	SA
C364	C-CER,CHIP	2203-006208	SA
C366	C-CER,CHIP	2203-006208	SA
C400	C-CER,CHIP	2203-000585	SA
C401	C-CER,CHIP	2203-000995	SA
C402	C-CER,CHIP	2203-005482	SA
C403	C-CER,CHIP	2203-000585	SA
C404	C-CER,CHIP	2203-000233	SA
C406	C-CER,CHIP	2203-002677	SA
C407	C-CER,CHIP	2203-000885	SA
C408	C-CER,CHIP	2203-000995	SA
C409	C-CER,CHIP	2203-005061	SA
C410	C-CER,CHIP	2203-006201	SA
C411	C-CER,CHIP	2203-000233	SA
C412	C-CER,CHIP	2203-000885	SA
C413	C-CER,CHIP	2203-001072	SA
C414	C-CER,CHIP	2203-001178	SA
C415	C-CER,CHIP	2203-000885	SA
C416	C-CER,CHIP	2203-006201	SA
C417	C-CER,CHIP	2203-000885	SA
C418	C-CER,CHIP	2203-000940	SA
C419	C-CER,CHIP	2203-000885	SA
C420	C-CER,CHIP	2203-000885	SA
C421	C-CER,CHIP	2203-000940	SA
C422	C-TA,CHIP	2404-001352	SA
C423	C-CER,CHIP	2203-000233	SA
C424	C-CER,CHIP	2203-005061	SA
C425	C-CER,CHIP	2203-000233	SA
C426	C-CER,CHIP	2203-000885	SA
C429	C-CER,CHIP	2203-000438	SA
C430	C-CER,CHIP	2203-001259	SA
C431	C-CER,CHIP	2203-000438	SA
C432	C-CER,CHIP	2203-005234	SA
C434	C-CER,CHIP	2203-000254	SA
C435	C-CER,CHIP	2203-000254	SA
C436	C-CER,CHIP	2203-000233	SA
C437	C-CER,CHIP	2203-000679	SA
C438	C-CER,CHIP	2203-000679	SA
C439	C-CER,CHIP	2203-002687	SA
C440	C-CER,CHIP	2203-000254	SA
C441	C-CER,CHIP	2203-000885	SA
C442	C-CER,CHIP	2203-005480	SA
C443	C-CER,CHIP	2203-006190	SA
C445	C-CER,CHIP	2203-001072	SA
C446	C-CER,CHIP	2203-000940	SA
C447	C-CER,CHIP	2203-000254	SA
C448	C-CER,CHIP	2203-000679	SA
C449	C-CER,CHIP	2203-005061	SA

Electrical Parts List

Design LOC	Description	SEC CODE	STATUS
C450	C-CER,CHIP	2203-006201	SA
C451	C-CER,CHIP	2203-005482	SA
C452	C-CER,CHIP	2203-006324	SA
C453	C-CER,CHIP	2203-006208	SA
C454	C-CER,CHIP	2203-006190	SA
C455	C-CER,CHIP	2203-000138	SA
C500	C-CER,CHIP	2203-001072	SA
C501	C-CER,CHIP	2203-006427	SA
C502	C-CER,CHIP	2203-006427	SA
C503	C-CER,CHIP	2203-005061	SA
C504	C-CER,CHIP	2203-000254	SA
C505	C-CER,CHIP	2203-006190	SA
C506	C-CER,CHIP	2203-000885	SA
C507	C-TA,CHIP	2404-001374	SA
C508	C-CER,CHIP	2203-006427	SA
C511	C-CER,CHIP	2203-006093	SA
C512	C-CER,CHIP	2203-006093	SA
C513	C-CER,CHIP	2203-001072	SA
C514	C-CER,CHIP	2203-001072	SA
C515	C-CER,CHIP	2203-001072	SA
C516	C-CER,CHIP	2203-001072	SA
C517	C-CER,CHIP	2203-006093	SA
C518	C-CER,CHIP	2203-006093	SA
C519	C-CER,CHIP	2203-006093	SA
C520	C-CER,CHIP	2203-006093	SA
C522	C-CER,CHIP	2203-006137	SA
C523	C-CER,CHIP	2203-006201	SA
C524	R-CHIP	2007-000162	SA
C525	C-CER,CHIP	2203-006093	SA
C526	C-CER,CHIP	2203-005061	SA
C527	C-TA,CHIP	2404-001105	SA
C528	C-TA,CHIP	2404-001381	SA
C529	C-CER,CHIP	2203-006137	SA
C530	C-CER,CHIP	2203-001072	SA
C531	C-CER,CHIP	2203-000812	SA
C532	C-CER,CHIP	2203-001072	SA
C533	C-CER,CHIP	2203-006201	SA
C534	R-CHIP	2007-000162	SA
C535	C-CER,CHIP	2203-006093	SA
C536	C-CER,CHIP	2203-005061	SA
C537	C-TA,CHIP	2404-001105	SA
C538	C-CER,CHIP	2203-005061	SA
C539	C-TA,CHIP	2404-001105	SA
C540	C-CER,CHIP	2203-006093	SA
C541	C-CER,CHIP	2203-006093	SA
C542	C-CER,CHIP	2203-005061	SA
C543	C-TA,CHIP	2404-001105	SA
C544	C-CER,CHIP	2203-000254	SA
C545	C-CER,CHIP	2203-000628	SA
C546	C-CER,CHIP	2203-000386	SA

Design LOC	Description	SEC CODE	STATUS
C547	C-CER,CHIP	2203-000386	SA
C548	C-CER,CHIP	2203-000386	SA
C549	C-CER,CHIP	2203-000386	SA
C551	C-CER,CHIP	2203-000628	SA
C552	C-CER,CHIP	2203-000628	SA
C554	C-CER,CHIP	2203-000386	SA
C555	C-CER,CHIP	2203-000628	SA
C556	C-CER,CHIP	2203-000628	SA
C557	C-CER,CHIP	2203-000386	SA
C558	C-CER,CHIP	2203-000386	SA
C559	C-CER,CHIP	2203-000386	SA
C560	C-CER,CHIP	2203-000386	SA
C561	C-CER,CHIP	2203-000628	SA
C562	C-CER,CHIP	2203-006348	SA
C563	C-CER,CHIP	2203-006053	SA
C564	C-CER,CHIP	2203-006093	SA
C565	C-CER,CHIP	2203-000438	SA
CN1	CONNECTOR-FPC/FFC/PIC	3708-001912	SA
CN201	HEADER-BOARD TO BOARD	3711-005210	SA
CN204	CONNECTOR-BATTERY	3711-005732	SA
CN205	JACK-DC POWER	3722-002119	SA
CON10	CONNECTOR-CARD EDGE	3709-001344	SA
CON20	CONNECTOR-INTERFACE	3710-001611	SA
D201	DIODE-SWITCHING	0401-001110	SA
D202	DIODE-SWITCHING	0401-001110	SA
D203	DIODE-ARRAY	0407-001002	SA
D204	DIODE-TVS	0406-001178	SA
D205	DIODE-TVS	0406-001150	SA
D502	DIODE-SCHOTTKY	0404-001172	SA
D503	DIODE-SCHOTTKY	0404-001245	SA
D504	DIODE-SCHOTTKY	0404-001245	SA
EAR20	JACK-EAR PHONE	3722-002315	SA
F12	BEAD-SMD	3301-001342	SA
F301	FILTER-SAW	2904-001521	SA
F302	FILTER-SAW	2904-001519	SA
F303	FILTER-SAW	2904-001498	SA
F401	FILTER-SAW	2904-001499	SA
F402	DUPLEXER-FBAR	2910-000009	SA
F404	FILTER-SAW	2904-001474	SA
F405	DUPLEXER-SAW	2910-000007	SA
F500	FILTER-EMI/ESD	2901-001337	SA
F501	FILTER-EMI/ESD	2901-001337	SA
F502	FILTER-EMI/ESD	2901-001337	SA
F503	FILTER-EMI/ESD	2901-001337	SA
HEA50	HEADER-BOARD TO BOARD	3711-005550	SA
HEA50	HEADER-BOARD TO BOARD	3711-005618	SA
HEA50	HEADER-BOARD TO BOARD	3711-005728	SA
J3	CONNECTOR-FPC/FFC/PIC	3708-001880	SA
J4	SOCKET-BOARD TO BOARD	3710-002042	SA
L100	BEAD-SMD	3301-001342	SA

Electrical Parts List

Design LOC	Description	SEC CODE	STATUS
L101	BEAD-SMD	3301-001362	SA
L103	BEAD-SMD	3301-001659	SA
L200	INDUCTOR-SMD	2703-001786	SA
L201	INDUCTOR-SMD	2703-002775	SA
L202	INDUCTOR-SMD	2703-002775	SA
L203	BEAD-SMD	3301-001342	SA
L204	BEAD-SMD	3301-001120	SA
L205	BEAD-SMD	3301-001120	SA
L206	BEAD-SMD	3301-001729	SA
L207	BEAD-SMD	3301-001120	SA
L208	BEAD-SMD	3301-001120	SA
L300	BEAD-SMD	3301-001342	SA
L301	BEAD-SMD	3301-001729	SA
L302	INDUCTOR-SMD	2703-001733	SA
L303	INDUCTOR-SMD	2703-001990	SA
L304	INDUCTOR-SMD	2703-001734	SA
L305	INDUCTOR-SMD	2703-001734	SA
L306	INDUCTOR-SMD	2703-001734	SA
L307	INDUCTOR-SMD	2703-001749	SA
L308	INDUCTOR-SMD	2703-001751	SA
L309	INDUCTOR-SMD	2703-002208	SA
L310	INDUCTOR-SMD	2703-001938	SA
L311	INDUCTOR-SMD	2703-002198	SA
L312	INDUCTOR-SMD	2703-002208	SA
L313	INDUCTOR-SMD	2703-001724	SA
L314	INDUCTOR-SMD	2703-002281	SA
L316	BEAD-SMD	3301-001342	SA
L319	BEAD-SMD	3301-001342	SA
L321	INDUCTOR-SMD	2703-001748	SA
L322	INDUCTOR-SMD	2703-001786	SA
L323	INDUCTOR-SMD	2703-001734	SA
L324	INDUCTOR-SMD	2703-001734	SA
L400	INDUCTOR-SMD	2703-001749	SA
L401	BEAD-SMD	3301-001120	SA
L402	INDUCTOR-SMD	2703-002308	SA
L403	INDUCTOR-SMD	2703-001751	SA
L404	INDUCTOR-SMD	2703-001868	SA
L405	INDUCTOR-SMD	2703-002833	SA
L502	BEAD-SMD	3301-001342	SA
L503	BEAD-SMD	3301-001342	SA
L504	BEAD-SMD	3301-001342	SA
L505	BEAD-SMD	3301-001342	SA
L507	BEAD-SMD	3301-001342	SA
L508	BEAD-SMD	3301-001342	SA
L509	INDUCTOR-SMD	2703-002768	SA
L510	INDUCTOR-SMD	2703-002768	SA
OSC10	CRYSTAL-SMD	2801-004353	SA
OSC10	RESONATOR-CERAMIC	2802-001182	SA
OSC30	OSCILLATOR-VCO	2806-001348	SA
OSC30	OSCILLATOR-VCTCXO	2809-001277	SA

Design LOC	Description	SEC CODE	STATUS
OSC30	OSCILLATOR-VCTCXO	2809-001277	SA
OSC50	OSCILLATOR-CLOCK	2804-001492	SA
Q1	TR-DIGITAL	0504-001012	SA
Q2	TR-DIGITAL	0504-001012	SA
Q3	TR-DIGITAL	0504-001012	SA
Q301	TR-DIGITAL	0504-001140	SA
Q302	FET-SILICON	0505-001670	SA
R100	R-CHIP	2007-001313	SA
R105	R-CHIP	2007-000171	SA
R106	R-CHIP	2007-000171	SA
R107	R-CHIP	2007-000171	SA
R109	R-CHIP	2007-000143	SA
R110	R-CHIP	2007-000172	SA
R111	R-CHIP	2007-000171	SA
R113	R-CHIP	2007-000171	SA
R120	R-CHIP	2007-000140	SA
R121	R-CHIP	2007-000140	SA
R124	R-CHIP	2007-000148	SA
R125	R-CHIP	2007-000148	SA
R126	R-CHIP	2007-000141	SA
R128	R-CHIP	2007-000140	SA
R130	R-CHIP	2007-001339	SA
R132	R-CHIP	2007-000148	SA
R134	R-CHIP	2007-000169	SA
R135	R-CHIP	2007-000171	SA
R136	R-CHIP	2007-000171	SA
R137	R-CHIP	2007-000148	SA
R138	R-CHIP	2007-001339	SA
R140	R-CHIP	2007-000140	SA
R141	R-CHIP	2007-000156	SA
R142	R-CHIP	2007-000148	SA
R145	R-CHIP	2007-000140	SA
R146	R-CHIP	2007-007529	SA
R147	R-CHIP	2007-007107	SA
R155	R-CHIP	2007-000775	SA
R156	R-CHIP	2007-007313	SA
R157	R-CHIP	2007-000143	SA
R162	R-CHIP	2007-000140	SA
R163	R-CHIP	2007-001308	SA
R167	R-CHIP	2007-007306	SA
R168	R-CHIP	2007-000171	SA
R170	R-CHIP	2007-000140	SA
R173	R-CHIP	2007-000141	SA
R174	R-CHIP	2007-001341	SA
R175	R-CHIP	2007-000171	SA
R179	R-CHIP	2007-000162	SA
R18	R-CHIP	2007-007131	SA
R180	R-CHIP	2007-000171	SA
R19	R-CHIP	2007-000171	SA
R20	R-CHIP	2007-000151	SA

Electrical Parts List

Design LOC	Description	SEC CODE	STATUS
R202	R-CHIP	2007-007142	SA
R203	R-CHIP	2007-007142	SA
R204	R-CHIP	2007-007134	SA
R205	R-CHIP	2007-007138	SA
R206	R-CHIP	2007-000148	SA
R208	R-CHIP	2007-007107	SA
R209	R-CHIP	2007-009118	SA
R21	R-CHIP	2007-000151	SA
R210	R-CHIP	2007-000162	SA
R211	R-CHIP	2007-000148	SA
R212	R-CHIP	2007-007107	SA
R213	R-CHIP	2007-009117	SA
R215	R-CHIP	2007-000171	SA
R218	R-CHIP	2007-000140	SA
R22	R-CHIP	2007-000151	SA
R220	R-CHIP	2007-000242	SA
R222	R-CHIP	2007-000148	SA
R224	R-CHIP	2007-003006	SA
R225	R-CHIP	2007-003006	SA
R226	R-CHIP	2007-000758	SA
R229	R-CHIP	2007-003010	SA
R23	R-CHIP	2007-000171	SA
R230	R-CHIP	2007-007134	SA
R231	R-CHIP	2007-000140	SA
R232	R-CHIP	2007-003010	SA
R233	R-CHIP	2007-007134	SA
R234	R-CHIP	2007-000140	SA
R238	R-CHIP	2007-007134	SA
R240	R-CHIP	2007-007134	SA
R243	R-CHIP	2007-003010	SA
R244	R-CHIP	2007-003010	SA
R245	R-CHIP	2007-007107	SA
R300	R-CHIP	2007-001290	SA
R301	R-CHIP	2007-001290	SA
R302	R-CHIP	2007-007491	SA
R303	R-CHIP	2007-007314	SA
R304	R-CHIP	2007-000155	SA
R305	R-CHIP	2007-007314	SA
R306	R-CHIP	2007-000138	SA
R307	R-CHIP	2007-000138	SA
R308	R-CHIP	2007-000172	SA
R309	R-CHIP	2007-000171	SA
R310	R-CHIP	2007-000172	SA
R311	R-CHIP	2007-000171	SA
R312	R-CHIP	2007-000140	SA
R313	R-CHIP	2007-001298	SA
R314	R-CHIP	2007-000171	SA
R318	R-CHIP	2007-000138	SA
R324	R-CHIP	2007-000165	SA
R325	R-CHIP	2007-000169	SA

Design LOC	Description	SEC CODE	STATUS
R343	R-CHIP	2007-002970	SA
R344	R-CHIP	2007-003112	SA
R345	R-CHIP	2007-007092	SA
R346	R-CHIP	2007-000143	SA
R400	R-CHIP	2007-007309	SA
R401	R-CHIP	2007-000172	SA
R402	R-CHIP	2007-000172	SA
R403	R-CHIP	2007-000140	SA
R404	R-CHIP	2007-000148	SA
R405	R-CHIP	2007-000171	SA
R406	R-CHIP	2007-000140	SA
R407	R-CHIP	2007-000242	SA
R408	R-CHIP	2007-000171	SA
R409	R-CHIP	2007-000172	SA
R410	R-CHIP	2007-000172	SA
R411	R-CHIP	2007-002797	SA
R412	R-CHIP	2007-000171	SA
R413	R-CHIP	2007-000171	SA
R414	R-CHIP	2007-000148	SA
R502	R-CHIP	2007-007589	SA
R503	R-CHIP	2007-007943	SA
R504	R-CHIP	2007-007590	SA
R508	R-CHIP	2007-000171	SA
R511	R-CHIP	2007-000171	SA
R521	R-CHIP	2007-000143	SA
R522	R-CHIP	2007-000143	SA
R524	R-CHIP	2007-000171	SA
R539	R-CHIP	2007-000171	SA
R540	R-CHIP	2007-000171	SA
R541	R-CHIP	2007-000171	SA
R542	R-CHIP	2007-000171	SA
R543	R-CHIP	2007-000171	SA
R544	R-CHIP	2007-000171	SA
R545	R-CHIP	2007-000172	SA
R8	R-CHIP	2007-000170	SA
R9	R-CHIP	2007-000171	SA
TH101	THERMISTOR-NTC	1404-001165	SA
U10	IC-SENSOR	1209-001603	SA
U101	IC-MODEM	1205-002521	SA
U102	IC-MCP	1109-001307	SA
U104	IC-SENSOR	1209-001626	SA
U106	IC-CMOS LOGIC	0801-002529	SA
U107	IC-CMOS LOGIC	0801-000306	SA
U108	IC-POSI.FIXED REG.	1203-003787	SA
U201	IC-VOL. DETECTOR	1203-003408	SA
U202	FET-SILICON	0505-001889	SA
U203	IC-POWER SUPERVISOR	1203-003495	SA
U204	DIODE-ARRAY	0407-001038	SA
U205	IC-AUDIO AMP	1201-002241	SA
U208	IC-CMOS LOGIC	0801-002661	SA

Electrical Parts List

Design LOC	Description	SEC CODE	STATUS
U209	IC-ANALOG SWITCH	1001-001265	SA
U210	IC-ANALOG SWITCH	1001-001265	SA
U211	IC-DC/DC CONVERTER	1203-003670	SA
U301	IC-RECEIVER	1205-002721	SA
U302	IC-RECEIVER	1205-002265	SA
U306	BLUETOOTH MODULE	4709-001368	SA
U400	IC-TRANSMITTER	1205-002497	SA
U401	CONNECTOR-COAXIAL	3705-001358	SA
U402	IC-DC/DC CONVERTER	1203-003366	SA
U403	IC-POWER AMP	1201-002229	SA
U404	IC-POWER AMP	1201-002230	SA
U405	IC-ANALOG SWITCH	1001-001303	SA
U500	IC-DC/DC CONVERTER	1203-003433	SA
U501	IC-SWITCH	1205-002568	SA
U502	IC-POSI.FIXED REG.	1203-003734	SA
U503	IC ASIC-SPHA800	GH13-00030A	SA
U504	IC-POSI.FIXED REG.	1203-003734	SA
U511	IC-POSI.FIXED REG.	1203-003688	SA
U512	IC-POSI.FIXED REG.	1203-003815	SA
U515	R-CHIP	2007-008401	SA
U516	C-CER,CHIP	2203-001072	SA
U517	C-TA,CHIP	2404-001105	SA
U7	IC-SWITCH REG.	1203-003309	SA
U9	IC-SENSOR	1209-001613	SA
V1	VARISTOR	1405-001082	SA
V2	VARISTOR	1405-001082	SA
V201	VARISTOR	1405-001093	SA
V202	VARISTOR	1405-001093	SA
V203	VARISTOR	1405-001093	SA
V204	VARISTOR	1405-001093	SA
V205	DIODE-TVS	0406-001178	SA
V206	DIODE-TVS	0406-001178	SA
V207	DIODE-TVS	0406-001178	SA
V208	DIODE-TVS	0406-001178	SA
V209	VARISTOR	1405-001110	SA
V210	VARISTOR	1405-001110	SA
V3	VARISTOR	1405-001082	SA
V4	VARISTOR	1405-001082	SA
V5	VARISTOR	1405-001082	SA
V500	VARISTOR	1405-001119	SA
V501	VARISTOR	1405-001119	SA
V503	VARISTOR	1405-001119	SA
V504	VARISTOR	1405-001119	SA
V505	VARISTOR	1405-001082	SA
V507	VARISTOR	1405-001082	SA
V508	VARISTOR	1405-001082	SA
V6	VARISTOR	1405-001082	SA
ZD201	DIODE-ZENER	0403-001547	SA

